

# DigiGas-CD

Digital Carbon Dioxide Sensor (SDI-12 Interface)

Digital Carbon Dioxide Sensor (RS485 Interface)

## User Manual

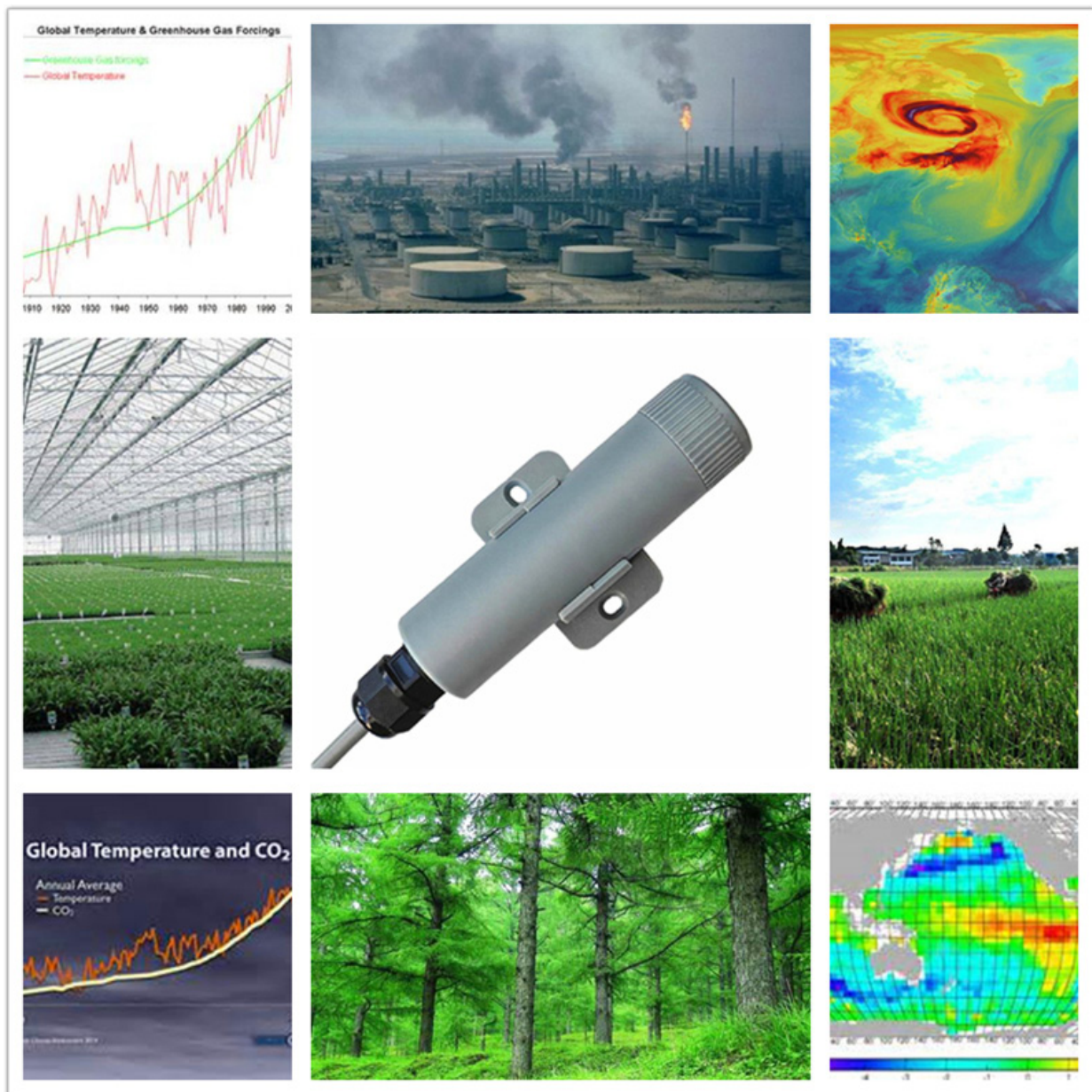

# Index

1 Customer Support.....	3
2 Introduction .....	4
<b>2.1 Brief.....</b>	<b>4</b>
<b>2.2 Accuracy .....</b>	<b>6</b>
<b>2.3 Operating mode and calibration.....</b>	<b>7</b>
2.3.1 Operating mode.....	7
2.3.2 Auto calibration.....	7
2.3.2 Force calibration .....	8
3 Wiring diagrams .....	9
<b>3.1 SDI-12 Interface .....</b>	<b>9</b>
<b>3.2 RS485 Interface .....</b>	<b>10</b>
4 Dimension and Ordering Infomation .....	11
<b>4.1 Dimension .....</b>	<b>11</b>
<b>4.2 Ordering Information.....</b>	<b>12</b>
5 SDI-12 Communication .....	13
<b>5.1 SDI-12 Interface and Protocol .....</b>	<b>15</b>
5.1.1 SDI-12 Interface.....	15
5.1.2 Protocol.....	15
6 RS485 Communication .....	22
<b>6.1 Modbus Protocol .....</b>	<b>22</b>
<b>6.2 Modbus Register .....</b>	<b>22</b>
<b>6.3 Modbus Register Detail Descripton .....</b>	<b>29</b>
7 FAQs.....	34
Appendix A SDI-12 Sensor Testing and Settings.....	35
<b>A.1 Testing SDI-12 Sensors with SDI12ELF20 Converter .....</b>	<b>35</b>
<b>A.2 Testing Example.....</b>	<b>36</b>
Appendix B RS485 Sensor Testing and Settings .....	38
<b>A.1 Testing RS485 Sensors with RS485 Converter.....</b>	<b>38</b>
<b>A.2 Testing Example.....</b>	<b>39</b>
Copyright and Trademark.....	41
Version Control.....	41

# 1 Customer Support

Thank you very much for your order. Our success comes from the continuous faith in the excellence of our products and services, something we are committed to and would never sacrifice. Our customer service, especially in the after sales phase, guarantees the satisfaction of our clients. In line with this strategy, we appreciate that you can share with us your feedback at any time for our improvement, be it positive or negative, so if we can serve you better in anyway, please do inform us.

## **Website**

<http://www.infwin.com>

## **E-Mail**

[infwin@163.com](mailto:infwin@163.com)

## **Telephone**

+86-411-66831953, +86-4000-511-521

## **Fax**

+86-411-66831953

## 2 Introduction

### 2.1 Brief

DigiGas-CD CO<sub>2</sub> sensor builds on the photoacoustic NDIR sensing principle to offer high accuracy at an unmatched price and smallest form factor. The sensor is applicable for science research, air conditioning, greenhouse, smart agriculture etc.

The SDI-12 output provides universal compatibility with any SDI-12-enabled data logger and low power applications, or use a RS485 physical interface for applications that require long cable runs or many sensors.

#### Features

- Integrated with SENSIRION SCD41 photoacoustic NDIR CO<sub>2</sub> sensor
- 10-years long life sensing with temperature and humidity compensation
- Digital Output SDI-12 or RS485 with built-in surge protection
- Small size with high accuracy with excellent stability
- Wall mounting installation
- Reverse power protection and Built-in TVS/ESD protection
- Excellent price-performance ratio

#### Applications

- Smart agriculture
- Greenhouse monitoring
- Air conditioning and ventilation control
- Routine weather monitoring

Specifications	
<b>Output Interface</b>	Optional: SDI-12, V1.3 Optional: RS485, Modbus-RTU
<b>Power Supply</b>	9-28V DC
<b>Power Consumption</b>	SDI-12 Interface: Quiescent Current: <10uA Measuring Current: 50mA@12VDC during 1000ms measurement, measurement interval 5000ms  RS485 Interface: Quiescent Current: <10mA Measuring Current :50mA@12VDC during 1000ms measurement, measurement interval 5000ms
<b>CO2 Accuracy</b>	Range: 0 ~ 5000ppm, Resolution: 1ppm Accuracy: 400 ~ 1000 ppm, ±(50 ppm + 2.5% Reading) Accuracy: 1001 ~ 2000 ppm, ±(50 ppm + 3% Reading) Accuracy: 2001 ~ 5000 ppm, ±(40 ppm + 5% Reading)
<b>Temperature Accuracy</b>	Range: -10 ~ 60°C, Resolution: 0.1°C Accuracy: 15 ~ 35°C, ±0.8°C Accuracy: -10 ~ 60°C, ±1.5°C
<b>Humidity Accuracy</b>	Range: 0-100%, Resolution: 0.1% 15 ~ 35 °C, 20 ~ 65 %RH , ±6 %RH -10 ~ 60 °C, 0 ~ 100 %RH, ±9 %RH
<b>Operating</b>	Temperature: -10 ~ 60°C, Humidity: 0-95% non-condensing
<b>IP Ratings</b>	IP50
<b>Installation</b>	Wall mounting
<b>Cable Length</b>	2 meters or Customize
<b>Dimension</b>	Sensor body: 111*25.5mm (Length*Diameter)

## 2.2 Accuracy

### CO2 Sensing Performance

Default conditions of 25 °C, 50 %RH, ambient pressure 1013 mbar, apply to values in the table below, unless otherwise stated.

Parameter	Conditions	Value
CO2 output range <sup>1</sup>	-	0~40'000 ppm
CO2 measurement accuracy <sup>2</sup>	400 ppm~1000 ppm 1001 ppm~2000 ppm 2001 ppm~5000 ppm	±(50 ppm + 2.5% of reading) ±(50 ppm + 3% of reading) ±(40 ppm + 5% of reading)
Repeatability	Typical	±10 ppm
Response time <sup>3</sup>	τ63%, typical	60 s
Additional accuracy drift after five years with automatic self-calibration (ASC) algorithm enabled <sup>4</sup>	Typical, 400~2000 ppm	±(5 ppm + 0.5 % of reading)

### Temperature Sensing Performance

Parameter	Conditions	Value
Temperature measurement range	-	- 10 °C~60 °C
Accuracy (typ.)	15 °C~35 °C -10 °C~60 °C	± 0.8 °C ± 1.5 °C
Repeatability	-	± 0.1 °C
Response time <sup>3</sup>	τ63%, typical	120 s
Accuracy drift	-	< 0.03 °C / year

### Humidity Sensing Performance

Parameter	Conditions	Value
Humidity measurement range	-	0 %RH~100 %RH
Accuracy (typ.)	15 °C~35 °C, 20 %RH~65 %RH -10 °C~60 °C, 0 %RH~100 %RH	±6 %RH ±9 %RH
Repeatability	Typical	±0.4 %RH
Response time <sup>3</sup>	τ63%, typical	90 s
Accuracy drift	-	<0.25 %RH / year

1. Exposure to CO2 concentrations smaller than 400 ppm can affect the accuracy of the sensor if the auto calibration function is on.
2. For proper function of the auto calibration algorithm, the sensor must be exposed to air with CO2 concentrations of 400 ppm on a weekly basis.
3. In final application, self-heating of the sensor and the environment around the sensor impacts the accuracy of the RH/T sensor.

## 2.3 Operating mode and calibration

### 2.3.1 Operating mode

The sensor has two operating modes, continuous measurement mode and request measurement mode, which are characterized as follows:

Interface	Operating Mode	Mode entry condition	Features
RS485	continuous measurement	The sensor enters continuous measurement mode after it is powered on	The CO2 sensor is continuously powered on and updates data every 5 seconds.
SDI-12	continuous measurement	(1) <+WarmUpTime>=6 when power on (2) Set <+WarmUpTime> to 6 using command	The CO2 sensor is continuously powered on and updates data every 5 seconds.
	request measurement	(1) <+WarmUpTime>is not 6 when power on (2) Set <+WarmUpTime> not equal to 6 using command	After receiving the measurement command, the CO2 sensor is powered on and preheated, and the preheating time is set by <+WarmUpTime>. After preheating, the measurement is performed and the data is returned.

### 2.3.2 Auto calibration

The sensor has an automatic calibration function, which can be turned on or off and only takes effect when the sensor is in “Continuous Measurement Mode”. In order for the automatic calibration function field calibration algorithm to work properly, the sensor must be exposed to 400 ppm of CO2 per week (in the atmosphere or in a well-ventilated space with outdoor ventilation).

Interface	Operating Mode	Auto Calibration	Condition
RS485	continuous measurement	Use the CO2_AUTOCLIBRATION register to turn on or off the auto calibration function.	The sensor must be exposed to 400 ppm of CO2 per week (in the atmosphere or in a well-ventilated space with outdoor ventilation)
SDI-12	continuous measurement	Use aXW_AUTOCALIB_<AutoCalibEnable>! Command to turn on or off the automatic calibration function.	
	request measurement	The sensor does not support automatic calibration when the Operating mode is “ request measurement”	N/A



## 2.3.2 Force calibration

The sensor has a forced calibration function. Put the sensor in an environment with known and uniform carbon dioxide concentration (reference gas) and execute the forced calibration instruction. After execution, the output value of the sensor is forced to be the concentration value of the reference gas.



Interface	Operating Mode	Force calibration function	Features
RS485	continuous measurement	Write to the CO2_FORCECLIBRATION register for forced calibration.	Forced calibration is required in an environment where CO2 concentration is known and uniform, if conditions are not available, the atmosphere can be used as a 400ppm standard gas for forced calibration.
SDI-12	continuous measurement request measurement	Use aXW_FORCECALIB_<ForceCalibValue>! Command for forced calibration.	

# 3 Wiring diagrams

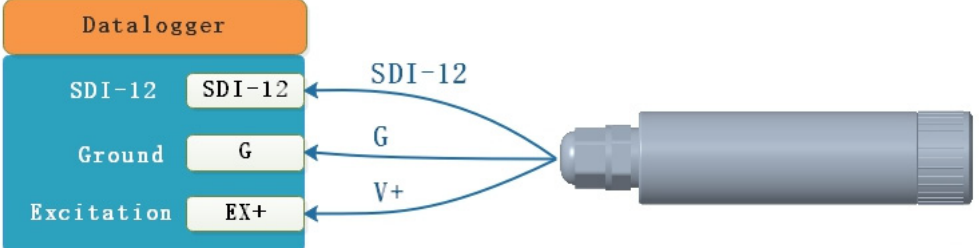
## 3.1 SDI-12 Interface

Type	Wiring diagram
<p><b>SDI-12 Interface</b></p>	<div style="background-color: #4a90e2; color: white; padding: 5px; margin-bottom: 10px; border-radius: 5px;">Cold pressed terminal</div>  <p>RED (V+) : Power Supply+</p> <p>BLACK (G) : Power supply-</p> <p>WHITE (SDI12) : SDI-12</p> <div style="background-color: #4a90e2; color: white; padding: 5px; margin-top: 10px; border-radius: 5px;">Tinned lead wires</div>  <p>RED (V+) : Power Supply+</p> <p>BLACK (G) : Power supply-</p> <p>WHITE (SDI12) : SDI-12</p>
<p><b>Connections</b></p>	<div style="background-color: #4a90e2; color: white; padding: 5px; margin-bottom: 10px; border-radius: 5px;">Wiring Diagram</div>  <p>Datalogger</p> <p>SDI-12    SDI-12</p> <p>Ground    G</p> <p>Excitation    EX+</p> <p>SDI-12</p> <p>G</p> <p>V+</p>

### 3.2 RS485 Interface

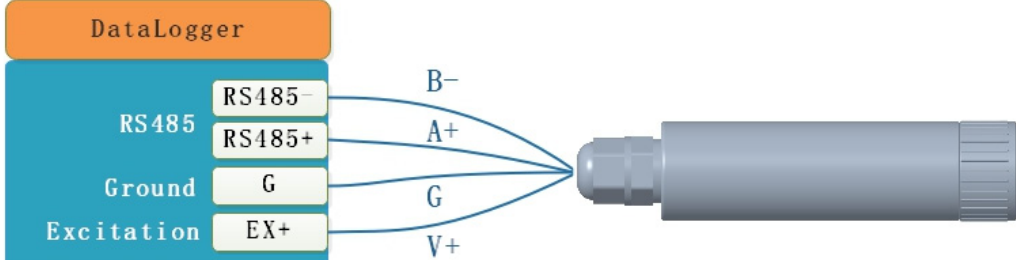
Type	Wiring diagram
<b>RS485 Interface</b>	<div style="background-color: #4F81BD; color: white; padding: 5px; text-align: center; margin-bottom: 10px;">Cold pressed terminal</div>  <div style="background-color: #4F81BD; color: white; padding: 5px; text-align: center; margin-top: 10px;">Tinned lead wires</div> 
<b>Connections</b>	<div style="background-color: #4F81BD; color: white; padding: 5px; text-align: center; margin-bottom: 10px;">Wiring Diagram</div> 

## 4 Dimension and Ordering Infomation

### 4.1 Dimension

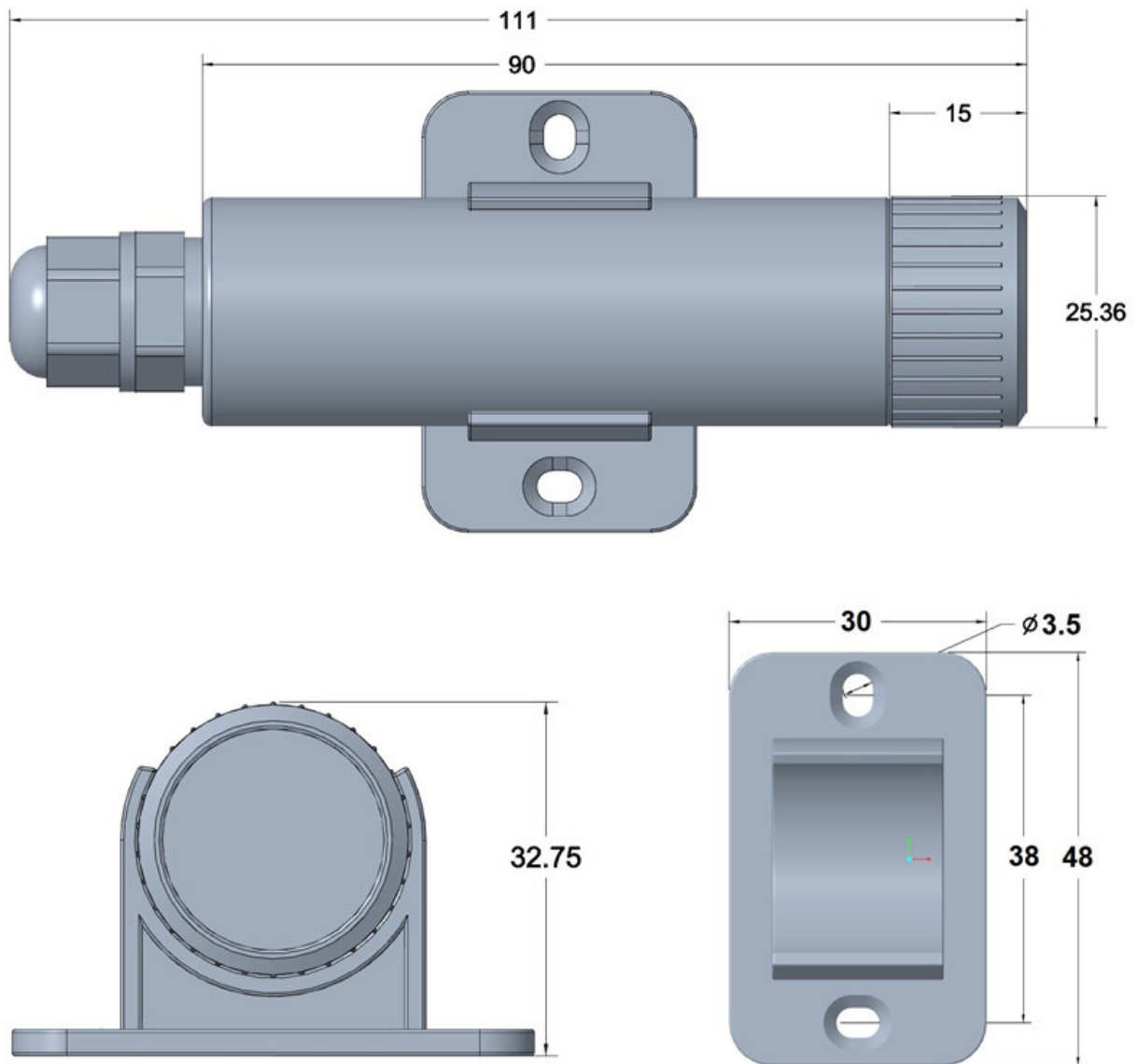

Unit: mm

## 4.2 Ordering Information

Parameters	Code	Comments
Code 1:Product Series	DigiGas-CD	DigiGas-CD, CO2, Air temperature, humidity sensor
Code 2: Range and Accuracy	A	0-5000ppm (Refer to specification for accuracy)
Code 3: Power Supply	A X	9-28V DC Customize
Code 4: Output Interface	A B	RS485(Modbus-RTU) SDI-12
Code 5: Connector	B C	Cold pressed terminal Stripped & tinned lead wires
Code 8: Cable Length	002 XXX	2 Meters Customize, XXX is required cable length (Unit: meter), Max 5 meters.
<p>Ordering Code Example: DigiGas-CD-A A A B 002</p> <p>Product Series: DigiGas-CD, CO2, Air temperature, humidity sensor;</p> <p>Range and Accuracy: 0-5000ppm (Refer to specification for accuracy);</p> <p>Power Supply: 9-28V DC</p> <p>Output Interface: RS485(Modbus-RTU);</p> <p>Connector: Cold pressed terminal;</p> <p>Cable Length: 2 Meters</p>		

## 5 SDI-12 Communication

The sensor has SDI-12 interface and protocol. The description and terms used within this chapter are listed in table below:

Parameters	Unit	Description
±	-	Sign of the value
a	-	SDI-12 address
n	-	Number of measurements (fixed width of 1)
nn	-	Number of measurements with leading zero if necessary (fixed width of 2)
ttt	Seconds	Maximum measurement time (fixed width of 3)
tttt	Seconds	Maximum measurement time (fixed width of 4)
<TAB>	-	Tab character
<SPACE>	-	Space character
<CR>	-	Carriage return character
<LF>	-	Line feed character
<Checksum>	-	SUM Checksum
<CRC_ADI>		ADI protocol CRC Checksum
<CRC>	-	SDI-12 protocol CRC Checksum
<VERIFY_STATUS>	-	Sensor Verification status
<+Gas>	ppm	Gas concentration(Original)
<+GasCalibed>	ppm	Gas concentration(Calibrated)
<+CO2Offset>	ppm	Gas concentration offset. Range: -1000~1000 Default: 0 $\langle +GasCalibed \rangle = \langle +Gas \rangle + \langle +CO2Offset \rangle$
<±Temperature>	°C °F	Temperature(Original), The value is output based on the temperature unit setting
<±TemperatureCalibed>	°C °F	Temperature(Calibrated), The value is output based on the temperature unit setting
<±TOffset>	°C °F	Temperature offset, The value is output based on the temperature unit setting Range: -10.00~10.00 Default: 0.00 $\langle \pm TemperatureCalibed \rangle = \langle \pm Temperature \rangle + \langle \pm TOffset \rangle$
<+Humidity>	%	Humidity(Original).
<+HumidityCalibed>	%	Humidity(Calibrated).
<+HumiOffset>	%	Humidity offset Range: -10.00~10.00 Default: 0.00 $\langle +HumidityCalibed \rangle = \langle +Humidity \rangle + \langle +$

		HUMIOFFSET>
<±DewPoint>	°C °F	Dew point(Original), The value is output based on the temperature unit setting
<±DewPointCalibed>	°C °F	Dew point(Calibrated), The value is output based on the temperature unit setting
<TemperatureUnit>	°C °F	Temperature unit C: Degree Celsius(Default) F: Degree Fahrenheit
<AutoCalibEnable>	N/A	CO2 automatic calibration ON/OFF. Please refer to chapter “Operating mode and calibration”.  0: Auto calibration ON(Default). 1: Auto calibration OFF.  <b>Note: Automatic calibration function only takes effect when the sensor is in “Continuous Measurement Mode”( &lt;+WarmUpTime&gt;=6)</b>
<ForceCalibValue>	ppm	Force the output value of the sensor to be the concentration value of the reference gas. Please refer to chapter “Operating mode and calibration”.  Range: 0-5000 ppm
<ForceCalibResult>	N/A	Force calibration result 0: Success 1: Error
<ResetCalibResult>	N/A	Reset force calibration result. 0: Success 1: Error.
<+WarmUpTime>	Second	Warm up time. The warm up time of the sensor after receiving the measurement command. The sensor will perform a measurement and data is returned at the end of the warm up time. Range: 6-300(Seconds) Default: 30  <b>Note: When set to 6, the sensor will be in continuous measurement mode, and the power consumption will increase.</b>

The following error value will be responded as measurement value when there is error:

Error Value	Description
-9999	Sensor Broken

## 5.1 SDI-12 Interface and Protocol

### 5.1.1 SDI-12 Interface

Please refer to SDI-12 standard user manual V1.3.

### 5.1.2 Protocol

Request	Response	Comment
a!	a<CR><LF>  a: Sensor address	<b>Acknowledge Active</b>  <b>Example:</b> Request: 0! Response: 0<CR><LF>
aI!	allccccccmmmmmmvvvxxxxxxxxxx xxxx<CR><LF>  a: Sensor address II:SDI-12 Version Number ccccccc: 8 characters vendor identification mmmmmm: 6 characters specifying the sensor model number vvv: 3 characters specifying the sensor version xxxxxxxxxxxxx: 13 characters serial number <CR><LF>: terminates the response	<b>Send Identification</b>  <b>Example:</b> Request: 0I! Response: 013INFWIN DGGCD 4.1DigiGas- 46004<CR><LF>
?!	a<CR><LF>  a: Sensor address	<b>Sensor Address Query</b>  <b>Example:</b> Request: ?! Response: 0<CR><LF>
aAb!	b<CR><LF>  a:Current Sensor address b:New Sensor address	<b>Change Sensor address</b>  <b>Example:</b> Request: 0A1! Response: 1<CR><LF>
aM!, aMC!	a0104<CR><LF>  a: Sensor address	<b>Gas concentration calibrated, Temperature calibrated, Humidity calibrated, Dew Point calibrated Measurement</b>

	<p>010: Measurement data will be ready in 010 seconds, 4: Number of measurement data returned by aD0! &lt;CR&gt;&lt;LF&gt;: terminates the response</p> <p>aD0! Response data format: a&lt;+GasCalibed&gt;&lt;±TemperatureCalibe d&gt;&lt;+HumidityCalibed&gt;&lt;±DewPointC alibed&gt;[&lt;CRC&gt;]&lt;CR&gt;&lt;LF&gt;</p>	<p>&lt;+WarmUpTime&gt; is set to 10, the data will be ready in 10 seconds.</p> <p><b>Example:</b> Request: 0M! Response: 00104&lt;CR&gt;&lt;LF&gt; Response: 0&lt;CR&gt;&lt;LF&gt; Request: 0D0! Response: 0+433+23.33+27.12+3.36&lt;CR&gt;&lt;LF&gt;</p>
<p>aM1!, aMC1!</p>	<p>a0104&lt;CR&gt;&lt;LF&gt;</p> <p>a: Sensor address 010: Measurement data will be ready in 010 seconds 4: Number of measurement data returned by aD0! &lt;CR&gt;&lt;LF&gt;: terminates the response</p> <p>aD0! Response data format: a&lt;+Gas&gt;&lt;±Temperature&gt;&lt;+Humidity &gt;&lt;±DewPoint&gt;[&lt;CRC&gt;]&lt;CR&gt;&lt;LF&gt;</p>	<p><b>Gas concentration, Temperature, Humidity, Dew Point Measurement</b></p> <p>&lt;+WarmUpTime&gt; is set to 10, the data will be ready in 10 seconds.</p> <p><b>Example:</b> Request: 0M! Response: 00104&lt;CR&gt;&lt;LF&gt; Response: 0&lt;CR&gt;&lt;LF&gt; Request: 0D0! Response: 0+433+23.33+27.12+3.36&lt;CR&gt;&lt;LF&gt;</p>
<p>aC!, aCC!</p>	<p>a01004&lt;CR&gt;&lt;LF&gt;</p> <p>a: Sensor address 010: Measurement data will be ready in 010 seconds 04: Number of measurement data returned by aD0! &lt;CR&gt;&lt;LF&gt;: terminates the response</p> <p>aD0! Response data format: a&lt;+GasCalibed&gt;&lt;±TemperatureCalibe d&gt;&lt;+HumidityCalibed&gt;&lt;±DewPointC alibed&gt;[&lt;CRC&gt;]&lt;CR&gt;&lt;LF&gt;</p>	<p><b>Gas concentration calibrated, Temperature calibrated, Humidity calibrated, Dew Point calibrated Measurement</b></p> <p>&lt;+WarmUpTime&gt; is set to 10, the data will be ready in 10 seconds.</p> <p><b>Example:</b> Request: 0C! Response: 001004&lt;CR&gt;&lt;LF&gt; Request: 0D0! Response: 0+433+23.33+27.12+3.36&lt;CR&gt;&lt;LF&gt;</p>
<p>aC1!, aCC1!</p>	<p>a01004&lt;CR&gt;&lt;LF&gt;</p> <p>a: Sensor address 010: Measurement data will be ready in 010 seconds 04: Number of measurement data returned by aD0! &lt;CR&gt;&lt;LF&gt;: terminates the response</p>	<p><b>Gas concentration, Temperature, Humidity, Dew Point Measurement</b></p> <p>&lt;+WarmUpTime&gt; is set to 10, the data will be ready in 10 seconds.</p> <p><b>Example:</b> Request: 0C! Response: 001004&lt;CR&gt;&lt;LF&gt;</p>

	<p>aD0! Response data format:  a&lt;+Gas&gt;&lt;±Temperature&gt;&lt;+Humidity&gt;  &gt;&lt;±DewPoint&gt;[&lt;CRC&gt;]&lt;CR&gt;&lt;LF&gt;</p>	<p>Request: 0D0!  Response: 0+433+23.33+27.12+3.36&lt;CR&gt;&lt;LF&gt;</p>
aV!	<p>a0101&lt;CR&gt;&lt;LF&gt;</p> <p>a: Sensor address  010: Measurement data will be ready in 002 seconds  1: Number of measurement data  &lt;CR&gt;&lt;LF&gt;: terminates the response</p> <p>aD0! Response data format:  a&lt;VERIFY_STATUS&gt;&lt;CR&gt;&lt;LF&gt;</p>	<p><b>Sensor Verification Command (&lt;+WarmUpTime&gt; is set to 10)</b></p> <p><b>Example:</b>  Request: 0V!  Response: 00101&lt;CR&gt;&lt;LF&gt;  Response: 0&lt;CR&gt;&lt;LF&gt;  Request: 0D0!  Response: 0+0&lt;CR&gt;&lt;LF&gt;, “+0” indicate sensor normal, “+1” means sensor error.</p>
aD0! aD1! aD2!	<p>[&lt;svvvv&gt;&lt;svvvv&gt;&lt;svvvv&gt;...][&lt;CRC&gt;]&lt;CR&gt;&lt;LF&gt;</p> <p>[&lt;svvvv&gt;]: data value  [&lt;CRC&gt;]: Optional 3 characters CRC checksum,  &lt;CR&gt;&lt;LF&gt;:terminates the response</p>	<p>Send Data since the last aM, aMC, aC, aCC, aV command, The data returned depends on the command sent most recently.</p>
aR0!, aRC0!	<p>Response data format:  a&lt;+GasCalibed&gt;&lt;±TemperatureCalibed&gt;&lt;+HumidityCalibed&gt;&lt;±DewPointCalibed&gt;[&lt;CRC&gt;]&lt;CR&gt;&lt;LF&gt;</p>	<p><b>Gas concentration calibrated, Temperature calibrated, Humidity calibrated, Dew Point calibrated Measurement</b></p> <p>&lt;+WarmUpTime&gt; is set to 10, the data will be ready in 10 seconds.</p> <p><b>Example:</b>  Request: 0R0!  After 10 seconds.....  Response: 0+433+23.33+27.12+3.36&lt;CR&gt;&lt;LF&gt;</p>
aR1!, aRC1!	<p>Response data format:  a&lt;+Gas&gt;&lt;±Temperature&gt;&lt;+Humidity&gt;  &gt;&lt;±DewPoint&gt;[&lt;CRC&gt;]&lt;CR&gt;&lt;LF&gt;</p>	<p><b>Gas concentration, Temperature, Humidity, Dew Point Measurement</b></p> <p>&lt;+WarmUpTime&gt; is set to 10, the data will be ready in 10 seconds.</p> <p><b>Example:</b>  Request: 0R1!  After 10 seconds.....  Response: 0+433+23.33+27.12+3.36&lt;CR&gt;&lt;LF&gt;</p>
aR9!, aRC9!	<p>Response data format:  a&lt;+Gas&gt;&lt;+GasCalibed&gt;&lt;±Temperature&gt;&lt;±TemperatureCalibed&gt;&lt;+Humidity&gt;&lt;+HumidityCalibed&gt;&lt;±DewPoint&gt;</p>	<p><b>Gas concentration, Gas concentration calibrated, Temperature, Temperature calibrated, Humidity, Humidity calibrated, Dew Point, Dew Point calibrated Measurement</b></p>

	t<<±DewPointCalibed>[<CRC>]<C R><LF>	<+WarmUpTime> is set to 10, the data will be ready in 10 seconds.  <b>Example:</b> Request: 0R9! After 10 seconds..... Response: 0+437+437+22.11+22.11+28.20+28.20+2.87+2.87<C R><LF>
aXR_TUNIT!	aTUNIT=<TemperatureUnit> <X> is temperature unit: C: degrees Centigrade F: degrees Fahrenheit	<b>Query temperature unit</b> <b>Example:</b> Request: 0XR_TUNIT! Response: 0TUNIT=C<CR><LF>
aXW_TUNIT_<TemperatureUnit>!	aTUNIT=<TemperatureUnit>	<b>Configure temperature unit</b> <b>Example:</b> Request: 0XW_TUNIT_C! Response: 0TUNIT=C<CR><LF>
aXR_CO2OFFSET!	aCO2OFFSET=<±CO2Offset> <±CO2Offset>: CO2 offset value. Range: -1000~1000, Default: 0 , The offset value will be applied from the next measurement command.  <+GasCalibed> = <+Gas> + <+CO2Offset>	<b>Query CO2 offset value</b> <b>Example:</b> Request: 0XR_CO2OFFSET! Response: 0CO2OFFSET=+100<CR><LF>
aXW_CO2OFFSET_<±CO2Offset>!	aCO2OFFSET=<±CO2Offset>	<b>Configure CO2 offset value</b> <b>Example:</b> Request: 0XW_CO2OFFSET_+100! Response: 0CO2OFFSET=+100<CR><LF>
aXR_TOFFSET!	aTOFFSET=<±TOffset> <±TOffset>: Temperature offset value. Range: -10.00~10.00, Default: 0.00, The offset value will be applied from the next measurement command.  <±TemperatureCalibed> = <±Temperature> + <±TOffset>	<b>Query temperature offset value</b> <b>Example:</b> Request: 0XR_TOFFSET! Response: 0TOFFSET=+1.00<CR><LF>
aXW_TOFFSET_<±TOffset>!	aTOFFSET=<±TOffset>	<b>Configure temperature offset value</b> <b>Example:</b> Request: 0XW_TOFFSET_+1.00! Response: 0TOFFSET=+1.00<CR><LF>
aXR_HUMIOFFSET!	aHUMIOFFSET=<±HUMIOFFSET> <±HUMIOFFSET>: Humidity offset	<b>Query humidity offset value</b> <b>Example:</b>

	<p>value. Range: -10.00~10.00, Default: 0.00 The offset value will be applied from the next measurement command.</p> <p>&lt;+HumidityCalibed&gt; = &lt;+Humidity&gt; + &lt;+HUMIOFFSET&gt;</p>	<p>Request: 0XR_HUMIOFFSET! Response: 0HUMIOFFSET=+1.00&lt;CR&gt;&lt;LF&gt;</p>
aXW_HUMIOFFSET_<+HUMIOFFSET>!	aHUMIOFFSET=<+HUMIOFFSET>	<p><b>Configure humidity offset value</b> <b>Example:</b> Request: 0XW_HUMIOFFSET_+1.00! Response: 0HUMIOFFSET=+1.00&lt;CR&gt;&lt;LF&gt;</p>
aXR_WUT!	<p>aWUT=&lt;+WarmUpTime&gt; &lt;+WarmUpTime&gt;: The warm up time of the sensor after receiving the measurement command. The sensor will perform a measurement and data is returned at the end of the warm up time. Range: 6-300(Seconds), Default: 30</p> <p><b>Note: When set to 6, the sensor will be in continuous measurement mode, and the power consumption will increase.</b></p>	<p><b>Query warm up time</b> <b>Example:</b> Request: 0XR_WUT! Response: 0WUT=+10&lt;CR&gt;&lt;LF&gt;</p>
aXW_WUT_<+WarmUpTime>!	aWUT=<+WarmUpTime>	<p><b>Configure warm up time</b> <b>Example:</b> Request: 0XW_WUT_10! Response: 0WUT=+10&lt;CR&gt;&lt;LF&gt;</p>
aXR_AUTOCALIB!	<p>aAUTOCALIB=&lt;AutoCalibEnable&gt; &lt;AutoCalibEnable&gt;: 0: Auto calibration ON(Default). 1: Auto calibration OFF.</p> <p><b>Note: Automatic calibration function only takes effect when the sensor is in “Continuous Measurement Mode”( &lt;+WarmUpTime&gt;=6)</b></p>	<p><b>Query automatic calibration function ON/OFF</b> <b>Example:</b> Request: 0XR_AUTOCALIB! Response: 0AUTOCALIB=0&lt;CR&gt;&lt;LF&gt;</p>
aXW_AUTOCALIB_<AutoCalibEnable>!	aXW_AUTOCALIB_<AutoCalibEnable>	<p><b>Configure automatic calibration function ON/OFF</b> <b>Example:</b> Request: 0XW_AUTOCALIB_0! Response: 0AUTOCALIB=0&lt;CR&gt;&lt;LF&gt;</p>
aXW_FORCE	aFORCECALIB=<ForceCalibResult>	Force the output value of the sensor to be the

<p>CALIB_&lt;Force CalibValue&gt;!</p>	<p>, &lt;+GasCalibed&gt;!  &lt;ForceCalibResult&gt;: 0: Success 1: Error  &lt;ForceCalibValue&gt;: 0-5000ppm.  Force the output value of the sensor to be the concentration value of the reference gas. The sensor will warm up for 5 minutes when receiving the measurement command, then perform the force calibration, and then warm up for 5 minutes and return the operation result.</p>	<p>concentration value of the reference gas.  <b>Example:</b> Request: 0XW_FORCECALIB_1000! Response: 0PIs wait ~ 10 minutes After about 10 minutes Response: 0FORCECALIB=0, CO2=996&lt;CR&gt;&lt;LF&gt;</p>
<p>aXW_FORCE CALIBEX_&lt;ForceCalibValue&gt;!</p>	<p>aFORCECALIBEX=&lt;ForceCalibResult&gt;!  &lt;ForceCalibResult&gt;: 0: Success 1: Error  &lt;ForceCalibValue&gt;: 0-5000ppm.  Force the output value of the sensor to be the concentration value of the reference gas. The sensor will warm up for 5 minutes when receiving the measurement command, then perform the force calibration and return the operation result.</p>	<p><b>Reset force calibration</b> <b>Example:</b> Request: 0XW_FORCECALIBEX_2000! Response: 0PIs wait ~ 5 minutes After about 5 minutes Response: 0FORCECALIBEX=0&lt;CR&gt;&lt;LF&gt;</p>
<p>aXW_RESETCALIB!</p>	<p>aRESETCALIB=&lt;ResetCalibResult&gt;,&lt;CO2&gt;=&lt;GasCalibed&gt;  Reset the force calibration data then warm up for 5 minutes and perform a measurement and return the operation result.</p>	<p><b>Reset the force calibration</b> <b>Example:</b> Request: aXW_RESETCALIB! After about 5 minutes Response: 0RESETCALIB=0, 660&lt;CR&gt;&lt;LF&gt;</p>
<p>aXW_RESETCALIBEX!</p>	<p>aRESETCALIBEX=&lt;ResetCalibResult&gt;  Reset the force calibration data then return the operation result</p>	<p><b>Reset the force calibration immediately</b> <b>Example:</b> Request: aXW_RESETCALIBEX! Response: 0RESETCALIBEX=0&lt;CR&gt;&lt;LF&gt;</p>

	immediately.	
aXR_SN!	aSN=<ssssssss> <ssssssss> is 8-digits serial number	<b>Query serial number</b> <b>Example:</b> Request: 0XR_SN! Response: 0SN=12345678<CR><LF>
aXW_SN_<sss sssss>!	aSN=<ssssssss>	<b>Configure serial number</b> <b>Example:</b> Request: 0XW_SN_ABCDEFGH! Response: 0SN=ABCDEFGH <CR><LF>

# 6 RS485 Communication

## 6.1 Modbus Protocol

Modbus Protocol is widely used to establish master-slave communication between intelligent devices or sensors. A MODBUS message sent from a master to a slave contains the address of the slave, the function code (e.g. 'read register' or 'write register'), the data, and a check sum (LRC or CRC).

The sensor is RS485 interface with Modbus protocol. The default serial communication settings is slave address 1, modbus rtu, 9600bps, 8 databits and 1 stop bit. All communication settings can be changed with modbus command, and take effective after re-power up the sensor.

Following modbus function code are supported by sensor.

Modbus Function Code 0x03 : used for reading holding register.

Modbus Function Code 0x04 : used for reading input register.

Modbus Function Code 0x06 : used for writing single holding register.

Modbus Function Code 0x10: used for writing multiple holding register.

## 6.2 Modbus Register

Parameters	Register Addr. (HEX/DEC)	Data Type	Modbus Function Code(DEC)	Range and Comments	Default Value
CO2 concentration(Calibrated) GAS_CALIBED	0x0000 /0	UINT16 RO	3/4	0-40000 mapping to 0-40000ppm	N/A
Temperature(Calibrated) TEMPRATURE_CALIBED	0x0001 /1	INT16 RO	3/4	-4000-12500 mapping to -40.00-125.00 (°C); -4000-25700 mapping to -40.00-257.00 (°F)	N/A
Humidity(Calibrated) HUMIDITY_CALIBED	0x0002 /2	INT16 RO	3/4	0-10000 mapping to 0.00-100.00 (%)	N/A
Dew point(Calibrated) DEWPOINT_CALIBED	0x0003 /3	INT16 RO	3/4	-10000-12500 mapping to -100.00-125.00 (°C) -14800-25700 mapping	N/A

				to -148.00-257.00 (°F)	
RESERVED	0x0004 /4	INT16 RO	3/4	Reserved	0
RESERVED	0x0005 /5	INT16 RO	3/4	Reserved	0
RESERVED	0x0006 /6	INT16 RO	3/4	Reserved	0
RESERVED	0x0007 /7	INT16 RO	3/4	Reserved	0
RESERVED	0x0008 /8	INT16 RO	3/4	Reserved	0
RESERVED	0x0009 /9	INT16 RO	3/4	Reserved	0
RESERVED	0x000A /10	INT16 RO	3/4	Reserved	0
RESERVED	0x000B /11	INT16 RO	3/4	Reserved	0
RESERVED	0x000C /12	INT16 RO	3/4	Reserved	0
RESERVED	0x000D /13	INT16 RO	3/4	Reserved	0
RESERVED	0x000E /14	INT16 RO	3/4	Reserved	0
RESERVED	0x000F /15	INT16 RO	3/4	Reserved	0
CO2 concentration(Original ) GAS	0x0010 /16	UINT16 RO	3/4	0-40000 mapping to 0- 40000ppm	N/A
Temperature(Original) TEMPRATURE	0x0011 /17	INT16 RO	3/4	-4000-12500 mapping to -40.00-125.00 (°C); -4000-25700 mapping to -40.00-257.00 (°F)	N/A
Humidity(Original) HUMIDITY	0x0012 /18	INT16 RO	3/4	0-10000 mapping to 0.00-100.00 (%)	N/A
Dew point(Original) DEWPOINT	0x0013 /19	INT16 RO	3/4	-10000-12500 mapping to -100.00-125.00 (°C) -14800-25700 mapping to	N/A

				-148.00-257.00 (°F)	
RESERVED	0x0014 /20	INT16 RO	3/4	Reserved	0
RESERVED	0x0015 /21	INT16 RO	3/4	Reserved	0
RESERVED	0x0016 /22	INT16 RO	3/4	Reserved	0
RESERVED	0x0017 /23	INT16 RO	3/4	Reserved	0
RESERVED	0x0018 /24	INT16 RO	3/4	Reserved	0
RESERVED	0x0019 /25	INT16 RO	3/4	Reserved	0
RESERVED	0x001A /26	INT16 RO	3/4	Reserved	0
RESERVED	0x001B /27	INT16 RO	3/4	Reserved	0
RESERVED	0x001C /28	INT16 RO	3/4	Reserved	0
RESERVED	0x001D /29	INT16 RO	3/4	Reserved	0
RESERVED	0x001E /30	INT16 RO	3/4	Reserved	0
RESERVED	0x001F /31	INT16 RO	3/4	Reserved	0
Temperature Unit TEMPUNIT	0x0020 /32	UINT16 R/W	3/6/16	0: °C 1: °F	0
CO2 Offset CO2OFFSET	0x0021 /33	INT16 R/W	3/6/16	-1000 ~ 1000 mapping to -1000 ~ 1000ppm	0
Temperature Offset TOFFSET	0x0022 /34	INT16 R/W	3/6/16	-1000 ~ 1000 mapping to -10.00 ~ 10.00°C	0
Humidity Offset HUMIOFFSET	0x0023 /35	INT16 R/W	3/6/16	-1000 ~ 1000 mapping to -10.00 ~ 10.00%	0
Floating Point Register Byte Order FLOATBYTEORDE R	0x0024 /36	INT16 R/W	3/6/16	Configure floating point register byte order. 0: Big-endian [ABCD] 1: Little-endian[DCBA] 2: Big-endian byte swap [BADC]	3

				3: Little-endian byte swap[CDAB]	
CO2 automatic calibration CO2_AUTOCLIBRATION	0x0030 /48	UINT16 R/W	3/6/16	0: OFF 1: ON	0
CO2 force calibration CO2_FORCECLIBRATION	0x0031 /49	UINT16 R/W	3/6/16	Read: Always 0 Write: 0-5000 mapping to 0-5000ppm	N/A
Reset CO2 force calibration data CO2_RESETCLIBRATION	0x0032 /50	UINT16 R/W	3/6/16	Read: Always 0 Write: 0xFFFF, to reset the CO2 force calibration data	N/A
CO2 automatic calibration result CO2_AUTOCLIBRATION_RESULT	0x0040 /64	UINT16 R/W	3/4	0: Success Non Zero: Error	N/A
CO2 force calibration result CO2_FORCECLIBRATION_RESULT	0x0041 /65	UINT16 R/W	3/4	0: Success Non Zero: Error	N/A
Reset CO2 force calibration result CO2_AUTOCLIBRATION_RESULT	0x0042 /66	UINT16 R/W	3/4	0: Success Non Zero: Error	N/A
Modbus Slave Address ADDRESS	0x0200 /512	UINT16 R/W	3/6/16	0-255	1
RS485 baudrate BAUDRATE	0x0201 /513	UINT16 R/W	3/6/16	0-5 0: 1200bps 1: 2400bps 2: 4800bps 3: 9600bps 4: 19200bps 5: 38400bps	3: 9600bps
RS485 Protocol PROTOCOL	0x0202 /514	UINT16 R/W	3/6/16	0 0: Modbus RTU	0: Modbus RTU

RS485 parity PARITY	0x0203 /515	UINT16 R/W	3/6/16	0-2 0: NONE 1: EVEN 2: ODD	0: NONE
RS485 data bits DATABITS	0x0204 /516	UINT16 R/W	3/6/16	1 1: 8 bits	1: 8 bits
RS485 Stopbits STOPBITS	0x0205 /517	UINT16 R/W	3/6/16	0-1 0: 1 stopbit 1: 2 stopbits	0: 1 stopbit
Reserved RESERVED	0x0206 /518	UINT16 R/W	3/6/16	Reserved	0
Reserved RESERVED	0x0207 /519	UINT16 R/W	3/6/16	Reserved	0
User Defined Serial Number USERSN	0x0220 /544 0x0221 /545 0x0222 /546 0x0223 /547	UINT16 R/W	3/16	0x0000000000000000- 0xFFFFFFFFFFFFFFFF Those four registers should be read/write in one command.	N/A
CO2 concentration(Calibrated) GAS_CALIBED_FLOAT	0x1000 /4096	FLOAT RO	3/4	0-40000 mapping to 0- 40000ppm	N/A
Temperature(Calibrated) TEMPRATURE_CALIBED_FLOAT	0x1002 /4098	FLOAT RO	3/4	-4000-12500 mapping to -40.00-125.00 (°C); -4000-25700 mapping to -40.00-257.00 (°F)	N/A
Humidity(Calibrated) HUMIDITY_CALIBED_FLOAT	0x1004 /4100	FLOAT RO	3/4	0-10000 mapping to 0.00-100.00 (%)	N/A
Dew point(Calibrated) DEWPOINT_CALIBED_FLOAT	0x1006 /4102	FLOAT RO	3/4	-10000-12500 mapping to -100.00-125.00 (°C) -14800-25700 mapping to -148.00-257.00 (°F)	N/A

RESERVED_FLOAT	0x1008 /4104	FLOAT RO	3/4	Reserved	0
RESERVED_FLOAT	0x100A /4106	FLOAT RO	3/4	Reserved	0
RESERVED_FLOAT	0x100C /4108	FLOAT RO	3/4	Reserved	0
RESERVED_FLOAT	0x100E /4110	FLOAT RO	3/4	Reserved	0
RESERVED_FLOAT	0x1010 /4112	FLOAT RO	3/4	Reserved	0
RESERVED_FLOAT	0x1012 /4114	FLOAT RO	3/4	Reserved	0
RESERVED_FLOAT	0x1014 /4116	FLOAT RO	3/4	Reserved	0
RESERVED_FLOAT	0x1016 /4118	FLOAT RO	3/4	Reserved	0
RESERVED_FLOAT	0x1018 /4120	FLOAT RO	3/4	Reserved	0
RESERVED_FLOAT	0x101A /4122	FLOAT RO	3/4	Reserved	0
RESERVED_FLOAT	0x101C /4124	FLOAT RO	3/4	Reserved	0
RESERVED_FLOAT	0x101E /4126	FLOAT RO	3/4	Reserved	0
CO2 concentration(Original ) GAS_FLOAT	0x1020 /4128	FLOAT RO	3/4	0-40000 mapping to 0- 40000ppm	N/A
Temperature(Original) TEMPRATURE_FLO AT	0x1022 /4130	FLOAT RO	3/4	-4000-12500 mapping to -40.00-125.00 (°C); -4000-25700 mapping to -40.00-257.00 (°F)	N/A
Humidity(Original) HUMIDITY_FLOAT	0x1024 /4132	FLOAT RO	3/4	0-10000 mapping to 0.00-100.00 (%)	N/A
Dew point(Original) DEWPOINT_FLOAT	0x1026 /4134	FLOAT RO	3/4	-10000-12500 mapping to -100.00-125.00 (°C) -14800-25700 mapping to -148.00-257.00 (°F)	N/A

RESERVED_FLOAT	0x1028 /4136	FLOAT RO	3/4	Reserved	0
RESERVED_FLOAT	0x102A /4138	FLOAT RO	3/4	Reserved	0
RESERVED_FLOAT	0x102C /4140	FLOAT RO	3/4	Reserved	0
RESERVED_FLOAT	0x102E /4142	FLOAT RO	3/4	Reserved	0
RESERVED_FLOAT	0x1030 /4144	FLOAT RO	3/4	Reserved	0
RESERVED_FLOAT	0x1032 /4146	FLOAT RO	3/4	Reserved	0
RESERVED_FLOAT	0x1034 /4148	FLOAT RO	3/4	Reserved	0
RESERVED_FLOAT	0x1036 /4150	FLOAT RO	3/4	Reserved	0
RESERVED_FLOAT	0x1038 /4152	FLOAT RO	3/4	Reserved	0
RESERVED_FLOAT	0x103A /4154	FLOAT RO	3/4	Reserved	0
RESERVED_FLOAT	0x103C /4156	FLOAT RO	3/4	Reserved	0
RESERVED_FLOAT	0x103E /4158	FLOAT RO	3/4	Reserved	0

UINT16:16 bit unsigned integer

INT16:16bit signed integer

RO: Register is Read Only

R/W: Register is Read/Write

HEX: Hexadecimal (data with 0x/0X prefix)

DEC: Decimal

FLOAT: Floating point register, the byte order is configured by “Floating Point Register Byte Order, FLOATBYTEORDER” register. Please refer to “Modbus Register Detail Descripton” for more details.

The register value will be set as following when there is sensor error:

Error Value	Register Address	Error
65535	CO2 value	sensor broken
-32768	Temperature value	sensor broken
-32768	Humidity value	sensor broken
-32768	Dew point value	sensor broken

## 6.3 Modbus Register Detail Description

GAS_CALIBED: CO2 concentration(Calibrated), UINT16 GAS: CO2 concentration(Original), UINT16		
Range	0-40000 mapping to 0-40000ppm	Default: N/A
Parameter Save	N/A	

Note: CO2 concentration measurement value

GAS_CALIBED_FLOAT: CO2 concentration(Calibrated), FLOAT GAS_FLOAT: CO2 concentration(Original), FLOAT		
Range	-40.00-125.00 (Temperature Unit set to °C); -40.00-257.00 (Temperature Unit set to °F)	Default: N/A
Parameter Save	N/A	

Note: CO2 concentration measurement value. The byte order is configured by “Floating Point Register Byte Order, FLOATBYTEORDER” register.

TEMPEATURE_CALIBED: Temperature(Calibrated), INT16 TEMPERATURE: Temperature(Original), INT16		
Range	-4000-12500 mapping to -40.00-125.00 (Temperature Unit set to °C); -4000-25700 mapping to -40.00-257.00 (Temperature Unit set to °F)	Default: N/A
Parameter Save	N/A	

Note: Temperature measurement value

TEMPEATURE_CALIBED_FLOAT: Temperature(Calibrated), FLOAT TEMPERATURE_FLOAT: Temperature(Original), FLOAT		
Range	-40.00-125.00 (Temperature Unit set to °C); -40.00-257.00 (Temperature Unit set to °F)	Default: N/A
Parameter Save	N/A	

Note: Temperature measurement value. The byte order is configured by “Floating Point Register Byte Order, FLOATBYTEORDER” register.

HUMIDITY_CALIBED: Humidity(Calibrated), INT16 HUMIDITY: Humidity(Original), INT16		
Range	0-10000 mapping to 0.00-100.00 (%)	Default: N/A

Parameter Save	N/A	
----------------	-----	--

Note: Humidity measurement value

HUMIDITY_CALIBED_FLOAT: Humidity(Calibrated), FLOAT		
HUMIDITY_FLOAT: Humidity(Original), FLOAT		
Range	0.00-100.00 (%)	Default: N/A
Parameter Save	N/A	

Note: Humidity measurement value. The byte order is configured by “Floating Point Register Byte Order, FLOATBYTEORDER” register.

DEWPOINT_CALIBED: Dew point(Calibrated), INT16		
DEWPOINT: Dew point(Original), INT16		
Range	-10000-12500 mapping to -100.00-125.00 (Temperature Unit set to °C) -14800-25700 mapping to -148.00-257.00 (Temperature Unit set to °F)	Default: N/A
Parameter Save	N/A	

Note: Dew point measurement value

DEWPOINT_CALIBED_FLOAT: Dew point(Calibrated), FLOAT		
DEWPOINT_FLOAT: Dew point(Original), FLOAT		
Range	-100.00-125.00 (Temperature Unit set to °C); -148.00-257.00 (Temperature Unit set to °F)	Default: N/A
Parameter Save	N/A	

Note: Dew point measurement value. The byte order is configured by “Floating Point Register Byte Order, FLOATBYTEORDER” register.

TEMPUNIT: Temperature Unit		
Range	0: °C 1: °F	Default: 0
Parameter Save	YES	

Note: Temperature Unit.

CO2OFFSET: CO2 offset, INT16		
Range	-1000 ~ 1000 mapping to -1000 ~ 1000ppm	Default: 0
Parameter Save	YES	

Note: CO2 offset value

GAS\_CALIBED = GAS + CO2OFFSET;

GAS\_CALIBED\_FLOAT = GAS\_FLOAT + CO2OFFSET;

TOFFSET: Temperature Offset, INT16		
Range	-1000 ~ 1000 mapping to -10.00 ~ 10.00°C	Default: 0
Parameter Save	YES	

Note: Temperature Offset.

TEMPRATURE\_CALIBED = TEMPRATURE + TOFFSET;

TEMPRATURE\_CALIBED\_FLOAT = TEMPRATURE\_FLOAT + TOFFSET / 100.00;

HUMIOFFSET: Humidity Offset, INT16		
Range	-1000 ~ 1000 mapping to -10.00 ~ 10.00%	Default: 0
Parameter Save	YES	

Note: Humidity Offset.

HUMIDITY\_CALIBED = HUMIDITY + HUMIOFFSET;

HUMIDITY\_CALIBED\_FLOAT = HUMIDITY\_FLOAT + HUMIOFFSET / 100.00;

FLOATBYTEORDER : Floating Point Register Byte Order, INT16		
Range	0: Big-endian [ABCD] 1: Little-endian[DCBA] 2: Big-endian byte swap [BADC] 3: Little-endian byte swap[CDAB]	Default: 3
Parameter Save	YES	

Note: Configure floating point register byte order.

Example: The 123456.00 in IEC754 is 0x47F12000 (A=47, B=F1, C=20, D=00), then

0: Big-endian [ABCD]

1: Little-endian[DCBA]

2: Big-endian byte swap [BADC]

3: Little-endian byte swap[CDAB]

CO2_AUTOCLIBRATION: CO2 automatic calibration, UINT16		
Range	0: OFF 1: ON	Default: 0
Parameter Save	YES	

Note: CO2 automatic calibration ON/OFF. Please refer to chapter “Operating mode and calibration” for more information.

CO2_FORCECLIBRATION: CO2 force calibration, UINT16		
Range	0-5000 mapping to 0-5000ppm	Default: N/A
Parameter Save	YES	

Note: CO2 force calibration. Please refer to chapter “Operating mode and calibration” for more information.

CO2_RESETECLIBRATION: Reset CO2 force calibration, UINT16		
Range	Write 0xFFFF to this register to reset the force calibration data	Default: N/A
Parameter Save	YES	

Note: Reset CO2 force calibration, Please refer to chapter “Operating mode and calibration” for more information.

SLAVEADDRESS: Modbus Slave Address, UINT16		
Data Range	0-255	Default: 1
Parameter Storage	YES	

Note: Please power up the sensor to take effective after set.

BAUDRATE: Serial Comm Baudrate, UINT16		
Data Range	0-5 0:1200bps 1:2400bps 2:4800bps 3:9600bps 4:19200bps 5:38400bps	Default: 3
Parameter Storage	YES	

Note: Please power up the sensor to take effective after set.

PROTOCOL: Serial Comm Protocol, UINT16		
Data Range	0 0:Modbus RTU	Default: 0
Parameter Storage	YES	

Note: Please power up the sensor to take effective after set.

PARITY: Serial Comm Parity, UINT16		
------------------------------------	--	--

Data Range	0-2 0:NONE 1:EVEN 2:ODD	Default: 0
Parameter Storage	YES	

Note: Please power up the sensor to take effective after set.

DATABITS: Serial Comm Databits, UINT16		
Data Range	1 1:8 databits	Default: 1
Parameter Storage	YES	

Note: Please power up the sensor to take effective after set.

STOPBITS: Serial Comm Stopbits, UINT16		
Data Range	0-1 0:1 stopbit 1:2 stopbits	Default: 0
Parameter Storage	YES	

Note: Please power up the sensor to take effective after set.

USER_SN--- User Serial Number		
Data Range	0x0000000000000000-0xFFFFFFFFFFFFFFFF User Serial Number. These four registers should be read and write together from start address 0x0220 with quantity 4.	Default: N/A
Parameter Storage	YES	

## 7 FAQs

### **Question : When multiple sensors are tested together, the values are inconsistent.**

- (1) When multiple sensors are tested together, the sensing part of the sensor needs to be very close, and the data is read and compared after the gas is evenly diffused.
- (2) The accuracy of the sensor itself may cause the sensor output to be inconsistent, but the data are within the accuracy range.

### **Question : The CO2 concentration has been changing and unstable since power on.**

- (1) If the sensor is taken out of the package or placed in a new measurement environment, a certain gas concentration balance time is required, which depends on the flow of the ambient gas.
- (2) The concentration of CO2 in the room changes with breathing or ventilation.
- (3) The sensor can be placed in a sealed environment and tested after the concentration equalizes.

### **Question : How to calibrate the CO2 concentration ?**

The sensor supports automatic calibration and force calibration, please refer to chapter “Operating mode and calibration”.

- (1) The sensor has an automatic calibration function, which can be turned on or off and only takes effect when the sensor is in “Continuous Measurement Mode”. In order for the automatic calibration function field calibration algorithm to work properly, the sensor must be exposed to 400 ppm of CO2 per week (in the atmosphere or in a well-ventilated space with outdoor ventilation).
- (2) The sensor has a forced calibration function. Put the sensor in an environment with known and uniform carbon dioxide concentration (reference gas) and execute the forced calibration instruction. After execution, the output value of the sensor is forced to be the concentration value of the reference gas.

### **Question : What is the function of warm-up time for SDI-12 sensor ?**

After receiving the measurement instruction, the sensor will activate the measurement function to collect and process CO2 data, which usually takes a certain amount of time to make the data output smooth and stable. When the sensor and the environment under test reach the gas concentration balance, the warm up time is generally set to 30-60 seconds. The sensor responds to the measurement instruction after the end of the warm-up time.

# Appendix A SDI-12 Sensor Testing and Settings

The user can test the communication or set the parameters with the SDI-12 sensors in the following method.

- Use any kind of master device that supports the SDI-12 interface (such as data acquisition device, data logger, etc.) to communicate with the sensor or set the parameters.
- Use a computer to communicate with the sensor through the SDI-12 converter (such as the SDI12ELF20 converter) and to set the parameters.

This chapter mainly introduces the communication or parameter setting on a computer for sensor through the SDI-12 converter (SDI12ELF20).

## A.1 Testing SDI-12 Sensors with SDI12ELF20 Converter

SDI12ELF20 is a communication converter between USB master device and SDI-12 sensor. It supports bidirectional transparent transmission of SDI-12 communication data and is used to control or test SDI-12 compatible sensors or devices. The USB master device can be a computer, Raspberry PI and other hosts that support USB interface.

<b>SDI12ELF20 Converter User Manual</b>
<a href="https://www.infwin.com/sdi12elf20-sdi-12-to-usb-converter/">https://www.infwin.com/sdi12elf20-sdi-12-to-usb-converter/</a>

In this example, a computer is used as a USB host to connect the sensor through the SDI12ELF20 converter for SDI-12 communication test.

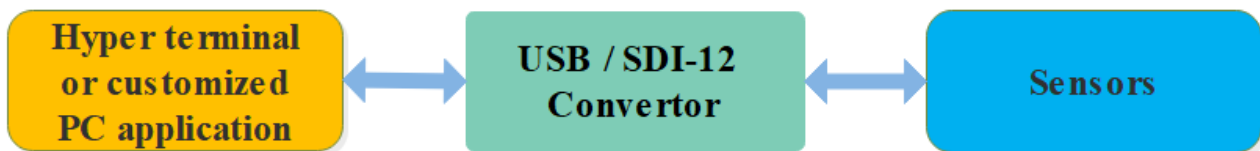

### Installation steps:

- Install USB Virtual COM port driver on PC, laptop or other USB master device. The converter uses the CH340C as the USB bridge chip. Download and install the CH340C driver and install it. After the converter is connected to the PC, a COM port is added to the system port. Use this port number in the debugging software to debug the communication with the converter.

<b>Driver Download</b>
<a href="https://www.infwin.com/resource-usb-to-serial-port-driver-ch340-series">https://www.infwin.com/resource-usb-to-serial-port-driver-ch340-series</a>

- Connect the converter to a PC, laptop or other USB master device through USB port

- Connect the sensor of the SDI-12 port to the converter
- The sensor can be powered by the power output that comes with the converter or by an external power supply which has common POWER GROUND with the converter power supply
- Users can use any serial communication software for SDI-12 communication, such as Terminal or HyperTerminal, The default communication parameters of SDI12ELF20 is 9600bps, none parity, 8 data bits, 1 stop bit. Please use ASCII mode to send and receive data.

Testing Software Download	
Terminal (universal serial port debugging tool)	<a href="https://www.infwin.com/resource-serial-port-com-development-tool/">https://www.infwin.com/resource-serial-port-com-development-tool/</a>
HyperTerminal (universal serial port debugging tool)	<a href="https://www.infwin.com/resource-serial-port-com-development-tool/">https://www.infwin.com/resource-serial-port-com-development-tool/</a>
SensorOneSetSDI12 (SDI-12 sensor configuration utility)	<a href="https://www.infwin.com/resource-sensoronesetsdi12-configuration-utility-for-sdi-12-sensors/">https://www.infwin.com/resource-sensoronesetsdi12-configuration-utility-for-sdi-12-sensors/</a>

## A.2 Testing Example

In this example, we use the SDI12ELF20 converter to communicate between a computer and the rugged temperature sensor DigiTEMP, The power supply of DigiTEMP is also provided by SDI12ELF20.

DigiTEMP Rugged Temperature Sensor User Manual
<a href="https://www.infwin.com/digitemp-rugged-digital-temperature-sensor-sdi12-rs485-modbus/">https://www.infwin.com/digitemp-rugged-digital-temperature-sensor-sdi12-rs485-modbus/</a>

### ■ Connections

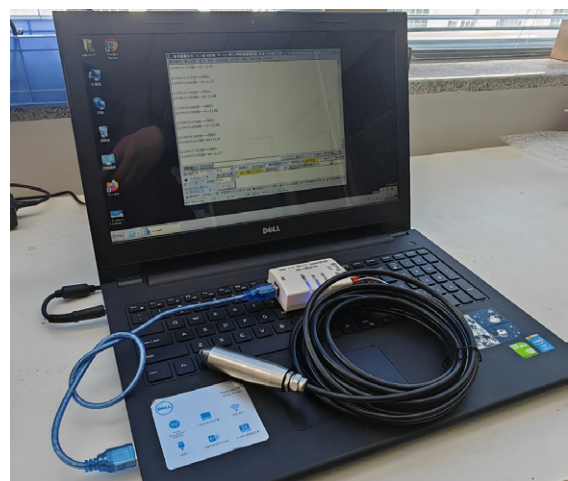

### ■ Testing with serial port utility “Terminal”

Take “Terminal” as an example, when debugging, please select the corresponding serial port number, baudrate is set to 9600bps, none parity, 8 data bits, 1 stop bit (the default communication

Settings of SDI12ELF20), open the serial port and input the SDI-12 command and send. Please note that the ASCII format should be used for data communication.

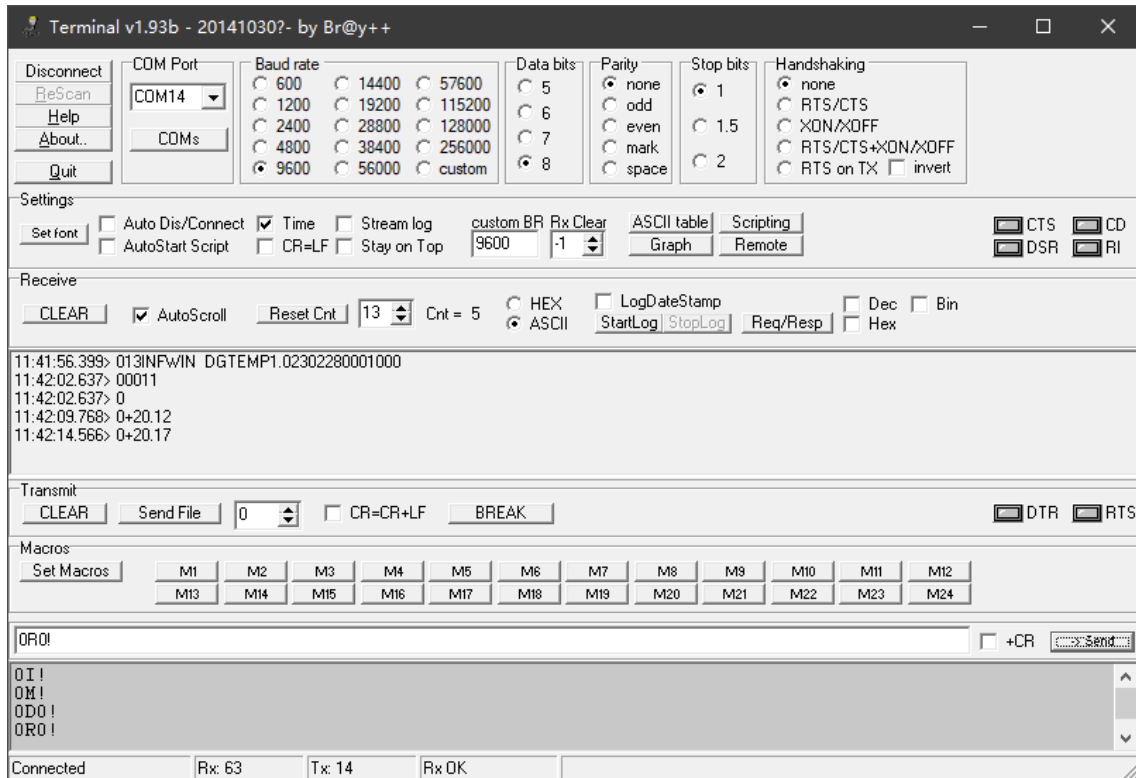

■ **Testing with SDI-12 sensor configuration utility “SensorOneSetSDI12”**

Start up the application, select the corresponding product page DigiTEMP, click "start communication" and choose the proper serial port number, 9600bps, none parity, 8 data bits, 1 stop bit (SDI12ELF20 default communication Settings) and start communication.

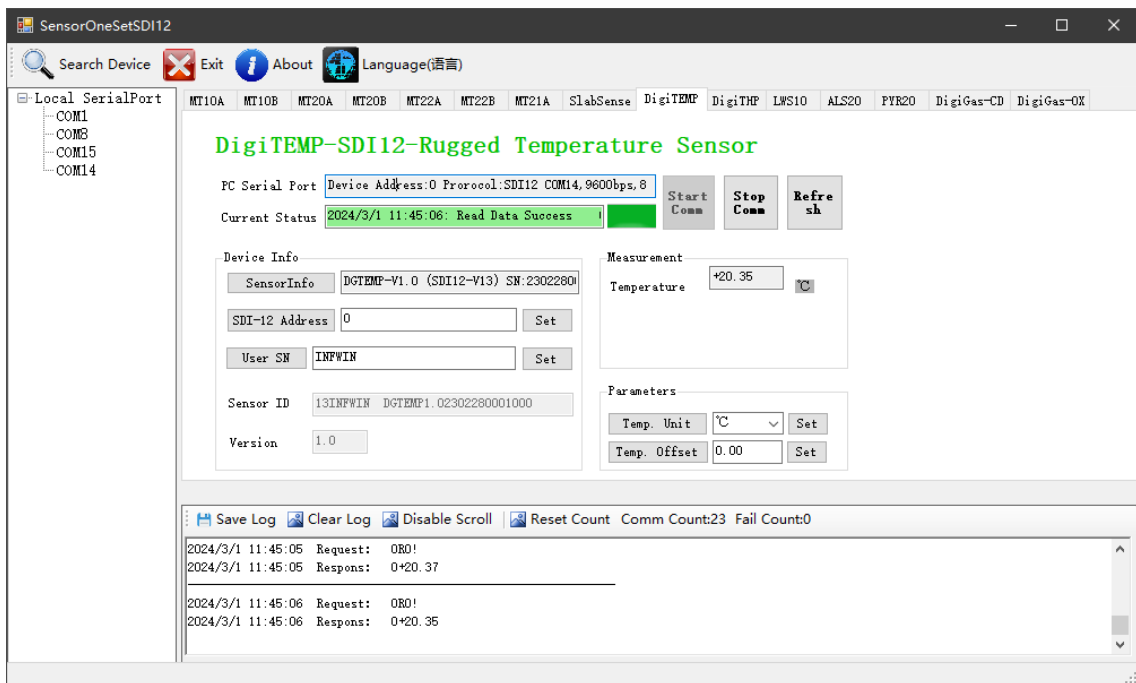

# Appendix B RS485 Sensor Testing and Settings

The user can test the communication or set the parameters with the SDI-12 sensors in the following method.

- Use any kind of master device that supports the SDI-12 interface (such as data acquisition device, data logger, etc.) to communicate with the sensor or set the parameters.
- Use a computer to communicate with the sensor through the SDI-12 converter (such as the SDI12ELF20 converter) and to set the parameters.

This chapter mainly introduces the communication or parameter setting on a computer for sensor through the SDI-12 converter (SDI12ELF20).

## A.1 Testing RS485 Sensors with RS485 Converter

SDI12ELF20 is a communication converter between USB master device and SDI-12 sensor. It supports bidirectional transparent transmission of SDI-12 communication data and is used to control or test SDI-12 compatible sensors or devices. The USB master device can be a computer, Raspberry PI and other hosts that support USB interface.

**SDI12ELF20 Converter User Manual**  
<https://www.infwin.com/sdi12elf20-sdi-12-to-usb-converter/>

In this example, a computer is used as a USB host to connect the sensor through the SDI12ELF20 converter for SDI-12 communication test.

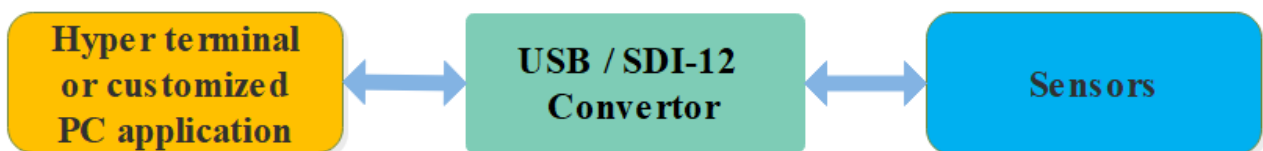

### Installation steps:

- Install USB Virtual COM port driver on PC, laptop or other USB master device. The converter uses the CH340C as the USB bridge chip. Download and install the CH340C driver and install it. After the converter is connected to the PC, a COM port is added to the system port. Use this port number in the debugging software to debug the communication with the converter.

**Driver Download**  
<https://www.infwin.com/resource-usb-to-serial-port-driver-ch340-series>

- Connect the converter to a PC, laptop or other USB master device through USB port

- Connect the sensor of the SDI-12 port to the converter
- The sensor can be powered by the power output that comes with the converter or by an external power supply which has common POWER GROUND with the converter power supply
- Users can use any serial communication software for SDI-12 communication, such as Terminal or HyperTerminal, The default communication parameters of SDI12ELF20 is 9600bps, none parity, 8 data bits, 1 stop bit. Please use ASCII mode to send and receive data.

Testing Software Download	
Terminal (universal serial port debugging tool)	<a href="https://www.infwin.com/resource-serial-port-com-development-tool/">https://www.infwin.com/resource-serial-port-com-development-tool/</a>
HyperTerminal (universal serial port debugging tool)	<a href="https://www.infwin.com/resource-serial-port-com-development-tool/">https://www.infwin.com/resource-serial-port-com-development-tool/</a>
SensorOneSetSDI12 (SDI-12 sensor configuration utility)	<a href="https://www.infwin.com/resource-sensoronesetsdi12-configuration-utility-for-sdi-12-sensors/">https://www.infwin.com/resource-sensoronesetsdi12-configuration-utility-for-sdi-12-sensors/</a>

## A.2 Testing Example

In this example, we use the SDI12ELF20 converter to communicate between a computer and the rugged temperature sensor DigiTEMP, The power supply of DigiTEMP is also provided by SDI12ELF20.

DigiTEMP Rugged Temperature Sensor User Manual
<a href="https://www.infwin.com/digitemp-rugged-digital-temperature-sensor-sdi12-rs485-modbus/">https://www.infwin.com/digitemp-rugged-digital-temperature-sensor-sdi12-rs485-modbus/</a>

### ■ Connections

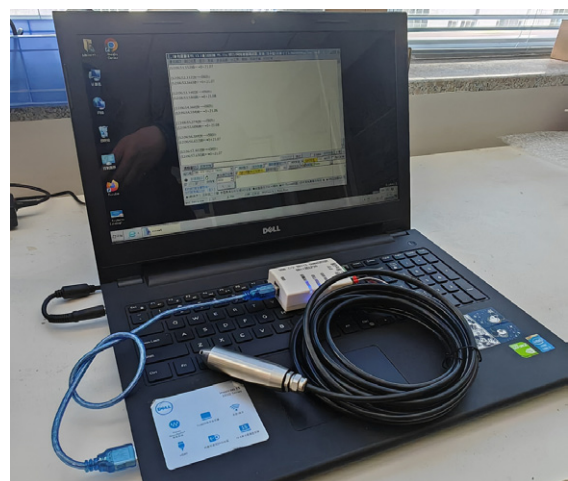

### ■ Testing with serial port utility “Terminal”

Take “Terminal” as an example, when debugging, please select the corresponding serial port number, baudrate is set to 9600bps, none parity, 8 data bits, 1 stop bit (the default communication

Settings of SDI12ELF20), open the serial port and input the SDI-12 command and send. Please note that the ASCII format should be used for data communication.

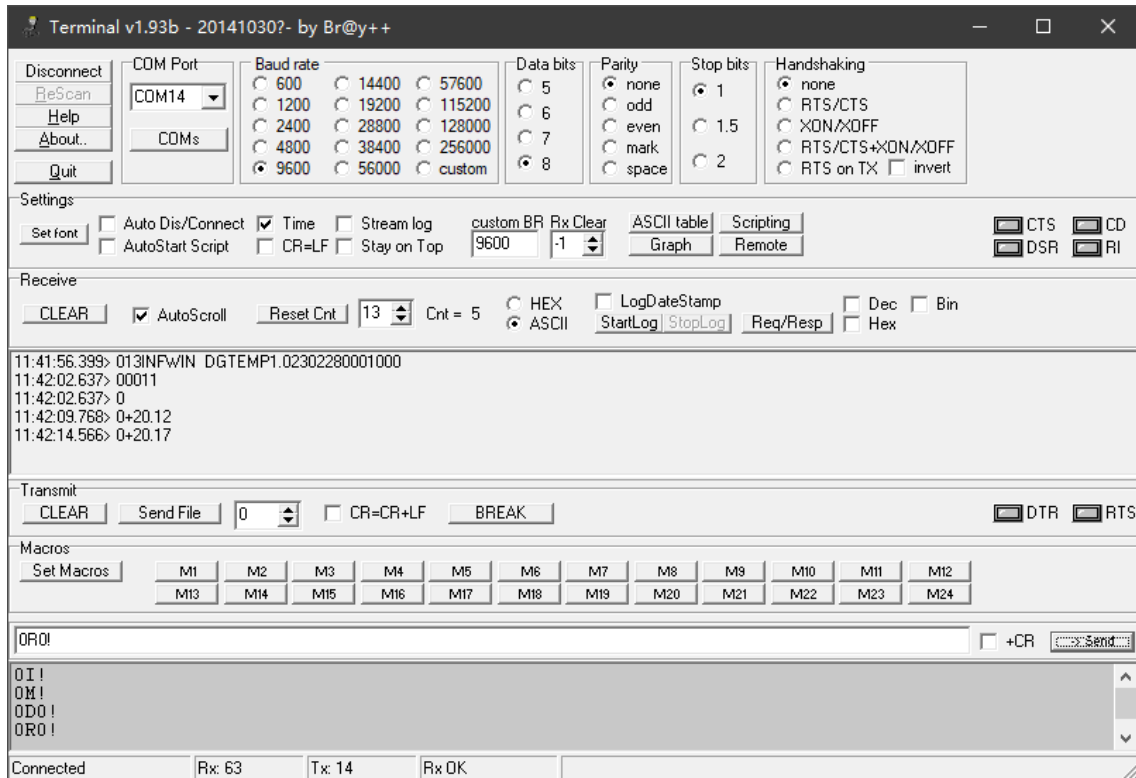

■ **Testing with SDI-12 sensor configuration utility “SensorOneSetSDI12”**

Start up the application, select the corresponding product page DigiTEMP, click "start communication" and choose the proper serial port number, 9600bps, none parity, 8 data bits, 1 stop bit (SDI12ELF20 default communication Settings) and start communication.

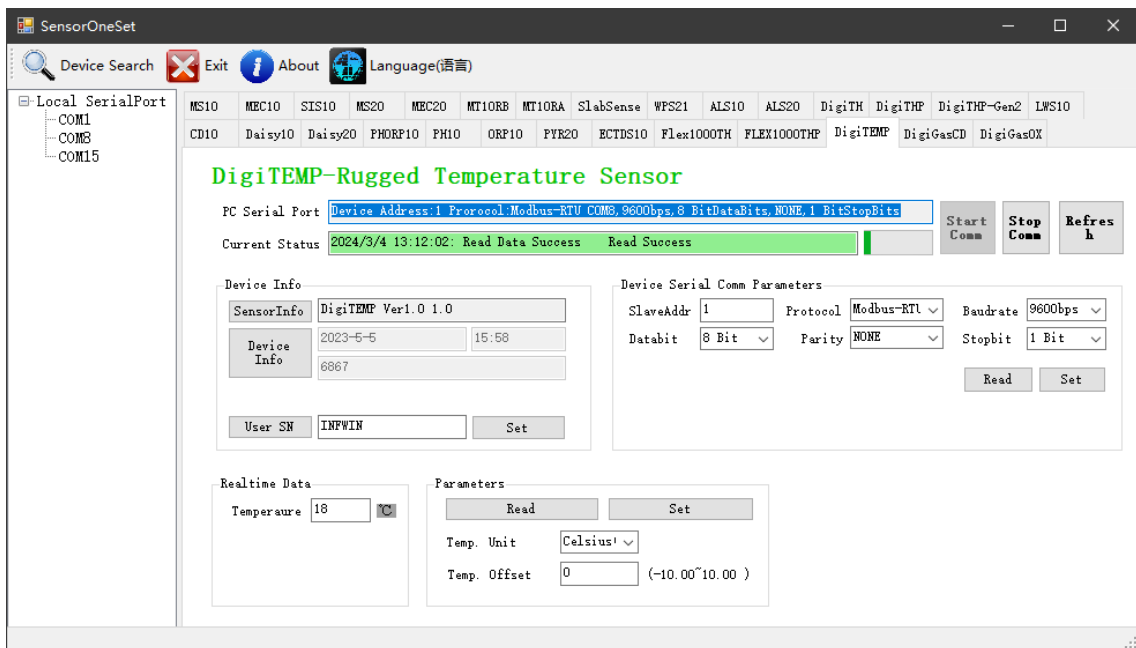

# Copyright and Trademark

This document is copyrighted, by Dalian Endeavour Technology Co., Ltd. All rights are reserved. Dalian Endeavour Technology Co., Ltd. reserves the right to make improvements to the products described in this manual at any time without notice. No part of this manual may be reproduced, copied, translated or transmitted in any form or by any means without the prior written permission. Information provided in this manual is intended to be accurate and reliable. However, Dalian Endeavour Technology Co., Ltd. assumes no responsibility for its use, nor for any infringements upon the rights of third parties, which may result from its use.

INFWIN® is the trademark of Dalian Endeavour Technology Co., Ltd.

# Version Control

Date	Version	Comment	Updated by
2024-04-23	V1.0	Initial Creation	sl51930