

MEC10

Soil Moisture, EC and Temperature Sensor User Manual

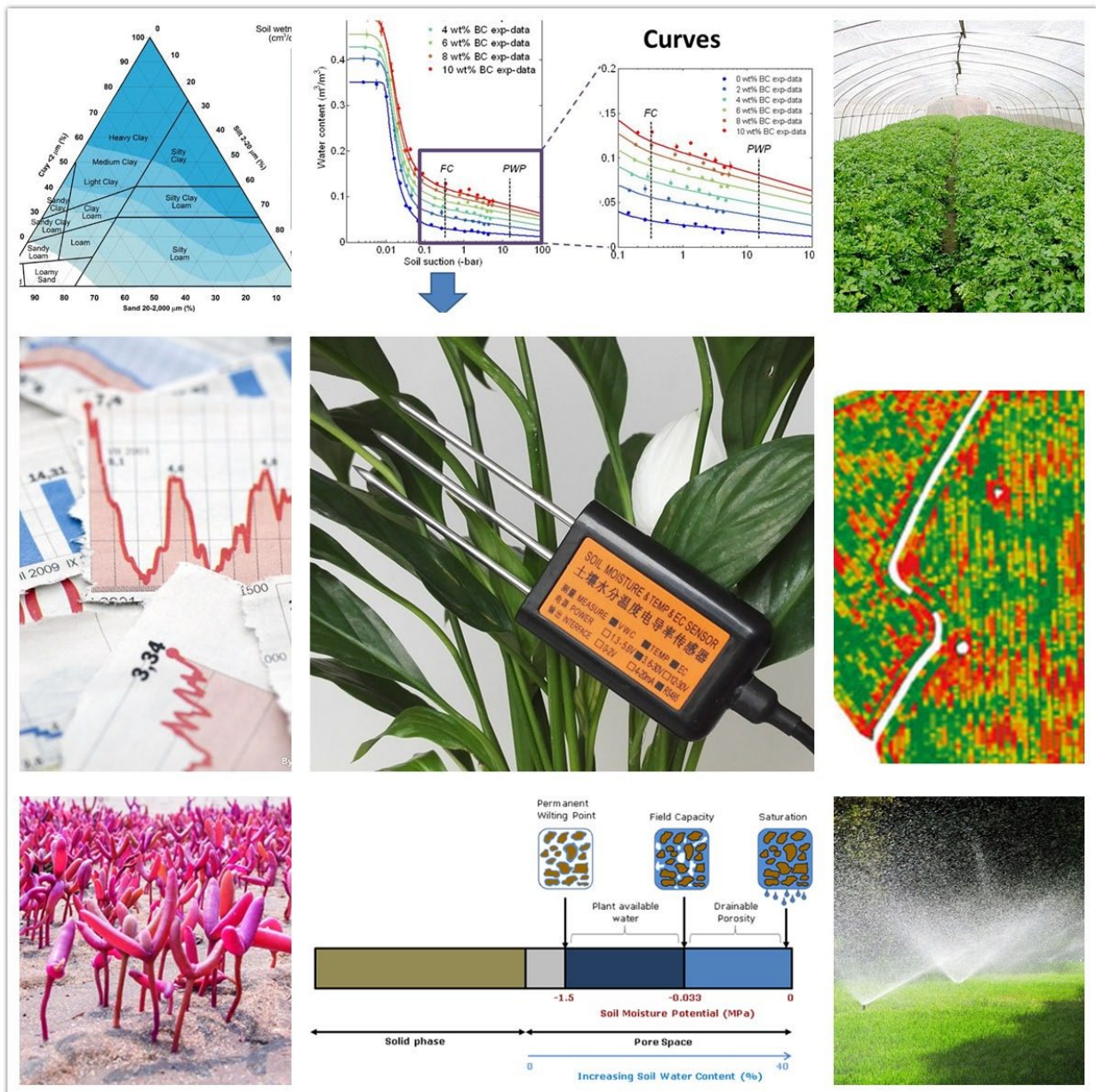

Index

1	Customer Support.....	3
2	Introduction	4
3	Wiring diagrams	5
4	Dimension and Ordering Infomation	7
	4.1 Dimension	7
	4.2 Ordering Infomation	7
5	Safty ,Care and Installation	9
	5.1 Care and Safty	9
	5.2 Installation	9
6	Output Signal Conversion	10
7	RS485 Modbus Protocol	11
	7.1 Modbus Protocol	11
	7.2 Modbus Register	11
	7.3 Modbus Register Detail Descripton	13
	7.4 Modbus Function Code	17
	7.4.1 Function Code 3 Protocol Example	17
	7.4.2 Function Code 4 Protocol Example	18
	7.4.3 Function Code 6 Protocol Example	19
	7.4.4 Function Code 16 Protocol Example	20
8	Software Configuration Utility.....	21
	8.1 Hardwar Setup	21
	8.2 Universal Modbus Comm Utility	22
	8.3 SensorOneSet Configuration Utility	22
	Appendix	23
	Copyright and Trademark	23
	Version Control	23

1 Customer Support

Thank you very much for your order. Our success comes from the continuous faith in the excellence of our products and services, something we are committed to and would never sacrifice. Our customer service, especially in the after sales phase, guarantees the satisfaction of our clients. In line with this strategy, we appreciate that you can share with us your feedback at any time for our improvement, be it positive or negative, so if we can serve you better in anyway, please do inform us.

Website

<http://www.infwin.com>

E-Mail

infwin@163.com

Telephone

+86-411-66831953, +86-4000-511-521

Fax

+86-411-82388125

2 Introduction

MEC10 measures soil moisture content, EC and temperature. It sealed with resin packaged plastic body with sensing rods which can be insert directly into the soil with long time stability. The soil moisture output signal can be RS485, Analog Voltage or Analog Current. It can also be calibrated for specific soils. The sensor is applicable for science research, irrigation, greenhouse, smart agriculture etc.

- Integrated with Soil Moisture, EC, Temperature measurement
- Output Interface with RS485, Voltage, Current
- Low salinity sensitivity
- Minimal soil disturbance
- Water proof to IP68 ratings and can be directly buried into soil
- High accuracy with excellent stability
- Reverse power protection and Built-in TVS/ESD protection

Specifications			
Output Interface	Analog Voltage 0-2V (Output resistance ~0ohm)	Analog Current 4-20mA (Load Resistor<500ohm)	RS485 Modbus-RTU
Power Supply	3.6-30V/DC	12-30V/DC	3.6-30V/DC
Power Consumption	6mA @24V DC	50mA @24V DC (with 2*20mA output signal)	6mA @24V DC
Soil Moisture Measurement	Range:0-50%,0-100% Resolution:0-50%:0.03%,50-100%:1% Accuracy:0-50%:3%,50-100%:5%		
EC Measurement	Range: 0-5000us/cm, 10000us/cm, 20000us/cm Resolution: 0-10000us/cm, 10us/cm; 10000-20000us/cm, 50us/cm Accuracy: 0-10000us/cm, ±3%; 10000-20000us/cm, ±5% EC temperature compensation: 0-50°C		
Temperature Measurement	Range: -40~80°C, Resolution:0.1°C, Accuracy:±0.5°C		
Measurement Technique	Moisture by FDR and EC by AC excitation		
IP Ratings	IP68		
Operating Temperature	-40~85°C		
Sensor Rod	Stainless steel		
Sensor Sealed	Epoxy resin		
Installation	Surface or buried installation		
Cable Length	2 meters or Customize		
Dimension	44*15*146mm		

3 Wiring diagrams

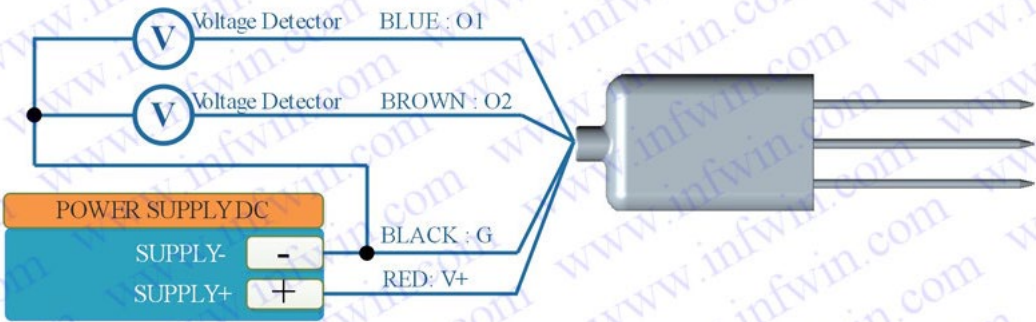
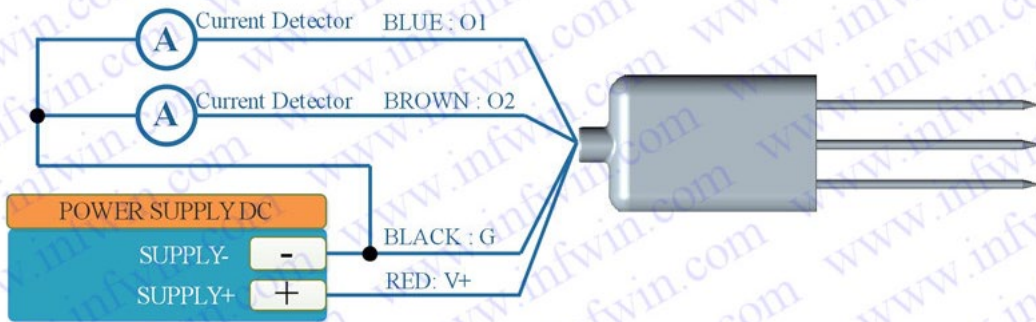
Type	Wiring diagram
Analog Voltage Output	<p>Red (V+): Power Supply + Black (G): Power Supply - Blue (O1): Analog Output (Can be set to VWC, EC, Temperature in factory) Brown (O2): Analog Output (Can be set to VWC, EC, Temperature in factory)</p> <p style="text-align: center;">Wiring Diagram for Analog Voltage Output 0-2V</p> 
Analog Current Output	<p>Red (V+): Power Supply + Black (G): Power Supply - Blue (O1): Analog Output (Can be set to VWC, EC, Temperature in factory) Brown (O2): Analog Output (Can be set to VWC, EC, Temperature in factory)</p> <p style="text-align: center;">Wiring Diagram for Analog Current Output 4-20mA</p> 
RS485 Modbus	<p>Red (V+): Power Supply + Black (G): Power Supply - Yellow (T+): RS485+/A/T+ White (T-): RS485-/B/T- Green (SET): SETTING mode. When sensor power-up with the SET wire connected to Power Supply +, then sensor using setting mode communication parameters for RS485. When sensor power-up with the SET wire connected to Power Supply - or unconnected, the sensor using communication parameters in register for RS485. Please refer to the usage below.</p>

Wiring Diagram for RS485 Modbus

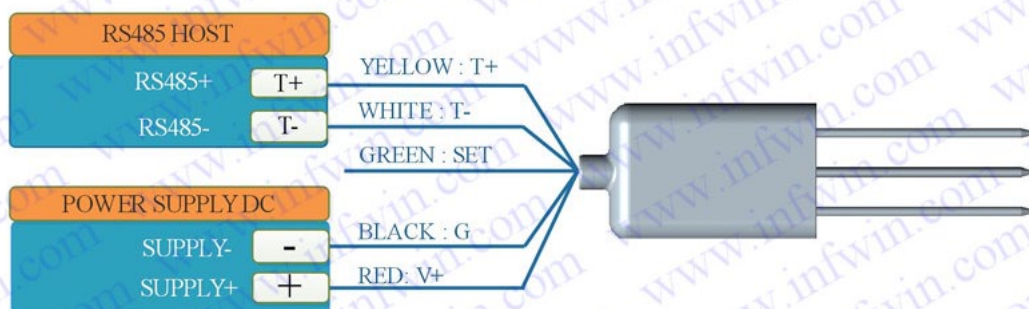

ALL RS485 communication parameters (Mosbus Slave Address, baudrate, parity, databits, stopbits) are set in internal register and can be saved when power down, the factory setting is ADDRESS=1, BAUDRATE=9600bps, PARITY=NONE, DATABITS=8bits, STOPBITS=1bit;

Sometimes you may FORGET the communication settings, In this case, you can connect the GREEN & RED wire together to PowerSupply+, black wire to PowerSupply-, then re-power up the sensor, then the sensor start-up with a fixed communication settings (we call it setting mode) ADDRESS=0, BAUDRATE=9600bps, PARITY=NONE, DATABITS=8bits, STOPBITS=1bit; Communicate with the sensor using this parameters and then set your desired communication parameters, then disconnect the green wire from PowerSupply+, then re-power up the sensor, and the sensor will communicate with your settings.

4 Dimension and Ordering Information

4.1 Dimension

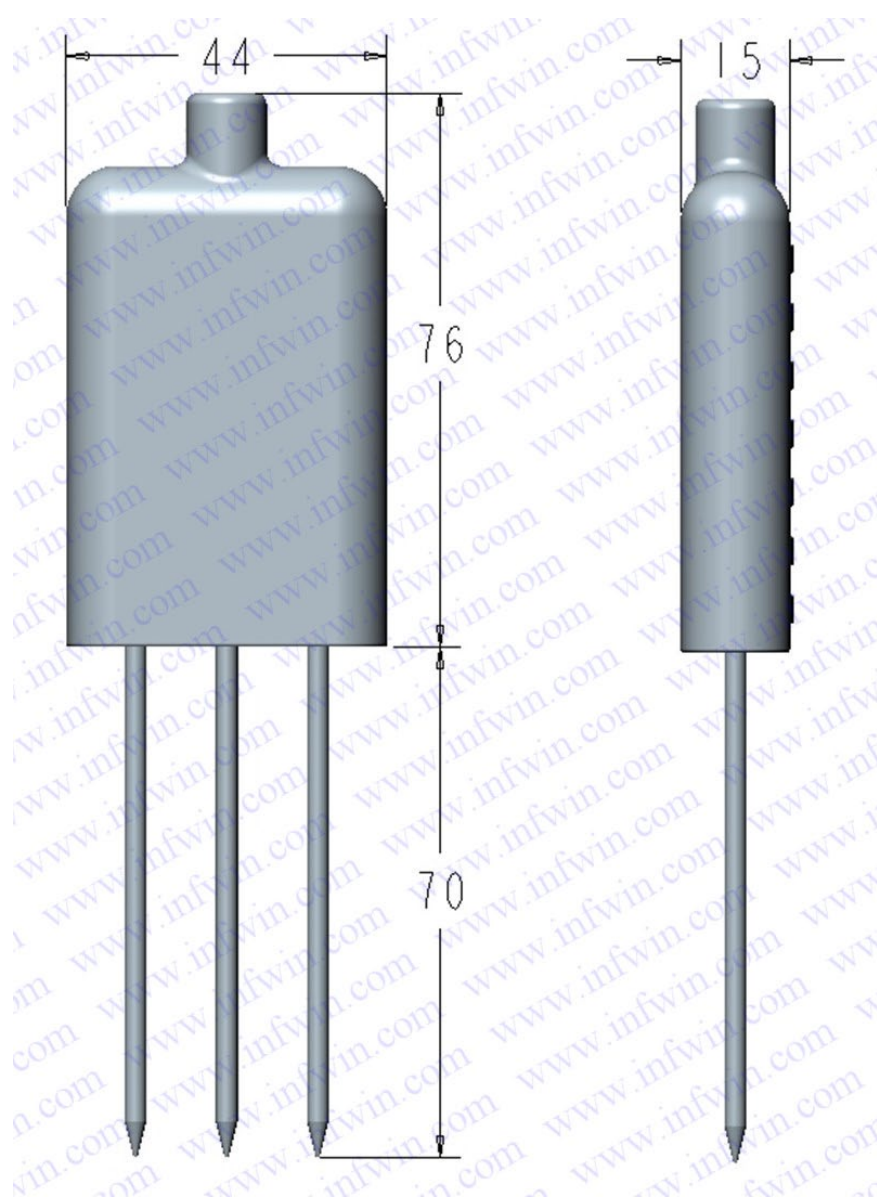

4.2 Ordering Information

Parameters	Code	Comments
Code 1: Product Series	MEC10	MEC10 Soil Moisture, EC, Temperature Sensor
Code 2: Measuring Parameters	A B C	Soil Moisture & Temperature & EC (only for RS485 output) Soil Moisture & EC Customize

Code 3: Soil Moisture Range	A	0-50%
	B	0-100%
Code 4: EC Range	A	0-5000us/cm
	B	0-10000us/cm
	C	0-20000us/cm
	D	Customize
Code 5: Power Supply	A	3.6-30V DC (not applicable for 4-20mA output)
	B	12-30V DC
	C	2.7-16V DC (not applicable for 4-20mA output)
	D	Customize
	E	2.0-5.5V DC (not applicable for 4-20mA output)
Code 6: Output Interface	A	Analog Voltage 0-2V
	B	Analog Current 4-20mA
	C	RS485,Modbus-RTU
	D	RS485,Modbus-RTU & Analog Voltage 0-2V
	E	RS485,Modbus-RTU & Analog Current 4-20mA
	F	SDI-12
	G	Customize
Code 7: Cable Length	002	2 meters
	XXX	Customize, XXX is required cable length(Unit: meter)
<p>Ordering Code Example: MEC10 Sensor with Soil Moisture & EC & Temperature parameters, Soil Moisture Range 100%, Soil EC Range 20000us/cm, Power Supply 3.6-30V DC, Output Interface RS485, Modbus-RTU, Cable Length 5 meters. Ordering Code is : MEC10 - A B C A C 005</p>		

5 Safty ,Care and Installation

5.1 Care and Safty

- The rods of the Sensor are sharp for ease insertion. Care must be taken and handling precautions followed.
- Avoid touching the rods or exposing them to other sources of static damage, particularly when powered up.
- Do not pull the sensor out of the soil by its cable.
- If you feel any resistance when inserting the sensor into soil, it is likely you have encountered a stone. Stop pushing and re-insert at a new location.

5.2 Installation

Surface installation

- Clear away any stones. Pre-form holes in very hard soils before insertion.
- Push the sensor into the soil until the rods are fully inserted. Ensure good soil contact.
- If you feel strong resistance when inserting the sensor, you have probably hit a stone. Stop, and re-insert at a new location.

Note: The sensor is suitable for soil surface temperature measurements.

Installing at depth

- Make a 45mm diameter hole, preferably at about 10° to the vertical using a auger.
- Push the sensor into the soil until rods are fully inserted. Ensure good soil contact.
- Fill and repack the hole with soil.

Alternatively

- Dig a trench, and install horizontally.

6 Output Signal Conversion

Output Interface	Parameters Range	Conversion Formula
Analog Voltage Output 0-2V	Temperature: -40-80℃	TEMP=60.0*VLOTAGE-40. When VOLTEGE=1.0V,then TEMP=60.0*1.0-40=20.00℃
	VWC: 0-50%	VWC=25*VOLTAGE. When VOLTAGE=0.3V,then VWC=25*0.3=7.5%
	VWC: 0-100%	VWC =50* VOLTAGE. When VOLTAGE=0.3V,then VWC =50*0.3=15%.
	EC: 0-5000us/cm	EC=2500*VOLTAGE. When VOLTAGE=0.3V,then EC=2500*0.3=750us/cm.
	EC: 0-10000us/cm	EC =5000* VOLTAGE. When VOLTAGE=0.3V,then EC =5000*0.3=1500us/cm.
	EC: 0-20000us/cm	EC =10000* VOLTAGE. When VOLTAGE=0.3V,then EC =10000*0.3=3000us/cm.
Analog Current Output 4-20mA	Temperature: -40-80℃	TEMP=7.5*CURRENT-70. When CURRENT=10mA, then TEMP=7.5*10-70=5.00℃.
	VWC: 0-50%	VWC= 3.125 *(CURRENT -4). When CURRENT=6.4mA, then VWC= 3.125*(6.4-4)=7.50%
	VWC: 0-100%	VWC = 6.25 *(CURRENT -4). When CURRENT=6.4mA, then VWC=6.25*(6.4-4)=15%
	EC: 0-5000us/cm	EC = 312.50 *(CURRENT -4). When CURRENT=6.4mA, then EC= 312.50*(6.4-4)=750us/cm
	EC: 0-10000us/cm	EC = 625 *(CURRENT -4). When CURRENT=6.4mA, then EC=625*(6.4-4)=1500us/cm
	EC: 0-20000us/cm	EC = 1250 *(CURRENT -4). When CURRENT=6.4mA, then EC=1250*(6.4-4)=3000us/cm
RS485 Modbus-RTU	Temperature: -40-80℃	TEMP=(REGISTER VALUE)/100. When REGISTER VALUE=2013, then TEMP= 2013/100=20.13℃.
	VWC for all ranges	VWC=(REGISTER VALUE)/100. When REGISTER VALUE=2013, then TEMP= 2013/100=20.13%.
	EC for all ranges	EC=(REGISTER VALUE). When REGISTER VALUE=1568, then EC= 1568us/cm.
Customize	Contact support for customized sensor interface	

NOTE:The unit of VOLTAGE is (V), The unit of CURRENT is (mA).

NOTE:VWC is Volumetric Water Content, EC is Electrical Conductivity.

7 RS485 Modbus Protocol

7.1 Modbus Protocol

Modbus Protocol is widely used to establish master-slave communication between intelligent devices or sensors. A MODBUS message sent from a master to a slave contains the address of the slave, the function code (e.g. 'read register' or 'write register'), the data, and a check sum (LRC or CRC).

The sensor is RS485 interface with Modbus protocol. The default serial communication settings is slave address 1, modbus rtu, 9600bps, 8 databits and 1 stop bit. All communication settings can be changed with modbus command, and take effective after re-power up the sensor.

Following modbus function code are supported by sensor.

Modbus Function Code 0x03 : used for reading holding register.

Modbus Function Code 0x04 : used for reading input register.

Modbus Function Code 0x06 : used for writing single holding register.

Modbus Function Code 0x10: used for writing multiple holding register.

7.2 Modbus Register

Parameters	Register Addr. (HEX/DEC)	Data Type	Modbus Function Code(DEC)	Range and Comments	Default Value
TEMPERATURE	0x0000 /0	INT16 RO	3/4	-4000-8000 for -40.00~80.00°C.	N/A
VWC-Volumetric Water Content	0x0001 /1	UINT16 RO	3/4	0-10000 for 0-100%	N/A
EC-Electrical Conductivity	0x0002 /2	UINT16 RO	3/4	0-20000 for 0-20000us/cm	N/A
SALINITY	0x0003 /3	UINT16 RO	3/4	0-20000 for 0-20000mg/L	N/A
TDS	0x0004 /4	UINT16 RO	3/4	0-20000 for 0-20000mg/L	N/A
EPSILON	0x0005 /5	UINT16 RO	3/4	88-8188 for 0.88-81.88	N/A
SOILTYPE	0x0020 /32	UINT16 R/W	3/6/16	0-3 0:Mineral 1:Sand	0:Mineral

				2:Clay 3:Organic	
TEMPUNIT	0x0021 /33	UINT16 R/W	3/6/16	0:°C 1:°F	0
ECTEMPCOFF	0x0022 /34	UINT16 R/W	3/6/16	0-100 for 0.0%-10.0%	20(2%)
SALINITYCOFF	0x0023 /35	UINT16 R/W	3/6/16	0-100 for 0.00-1.00	55(0.55)
TDSCOFF	0x0024 /36	UINT16 R/W	3/6/16	0-100 for 0.00-1.00	50(0.5)
MEASUREMETHOD	0x0025 /37	UINT16 R/W	3/6/16	0: Continuous Meas. 1: Request Meas.	1
SLAVEADDRESS	0x0200 /512	UINT16 R/W	3/6/16	0-255	1
BAUDRATE	0x0201 /513	UINT16 R/W	3/6/16	0-6 0:1200bps 1:2400bps 2:4800bps 3:9600bps 4:19200bps 5:38400bps	3:9600bps
PROTOCOL	0x0202 /514	UINT16 R/W	3/6/16	0-1 0:Modbus RTU 1:Modbus ASCii	0:Modbus RTU
PARITY	0x0203 /515	UINT16 R/W	3/6/16	0-2 0:None 1:Even 2:Odd	0:None Parity
DATABITS	0x0204 /516	UINT16 R/W	3/6/16	1 1:8 databits	1:8 databits
STOPBITS	0x0205 /517	UINT16 R/W	3/6/16	0-1 0:1 stopbit 1:2 stopbits	0:1 stopbit
RESPONSEDELAY	0x0206 /518	UINT16 R/W	3/6/16	0-255 for 0-2550 milliseconds	0
ACTIVEOUTPUTINTERVAL	0x0207 /519	UINT16 R/W	3/6/16	0-255 for 0-255 seconds.	0

NOTE: UINT16:16 bit unsigned integer, INT16:16bit signed integer

NOTE: RO: Register is Read Only, R/W: Register is Read/Write

NOTE: HEX is Hexadecimal (data with 0x/0X prefix), DEC is Decimal

7.3 Modbus Register Detail Descripton

TEMPERATURE		
Data Range	-4000-8000 For -40.00~80.00°C	Default: N/A
Power Down Save	N/A	

Note:Temperature value (Binary complement).

Example:When REGISTER = 0x0702 (HEX format), then

VALUE=(0x07*256+0x02)/100=17.94°C.When REGISTER=FF05H (HEX format),then

VALUE=((0xFF*256+0x05)-0xFFFF-0x01)/100 =(0xFF05-0xFFFF-0x01)/100=-2.51°C.

VWC ---Volmetric Water Content		
Data Range	0-10000 For 0-100%	Default: N/A
Power Down Save	N/A	

Note:Volmetric Water Content value.

Example:When REGISTER = 0x0702 (HEX format), then VALUE=(0x07*256+0x02)/100=17.94%

EC ---Electrical Conductivity		
Data Range	0-20000 For 0-20000us/cm	Default: N/A
Power Down Save	N/A	

Note:Electrical Conductivity.

Example:When REGISTER = 0x0702 (HEX format), then VALUE=(0x07*256+0x02)=1794us/cm

SALINITY--- Salinity		
Data Range	0-20000 For 0-20000mg/L	Default: N/A
Power Down Save	N/A	

Note:SALINITY

Example:When REGISTER = 0x0702 (HEX format), then VALUE=(0x07*256+0x02)=1794mg/L,

Salinity is derived by EC, SALINITY=EC* SALINITYCOFF, in which SALINITYCOFF is a coefficient, please refer to SALINITYCOFF.

TDS---Total Dissolved Solid		
Data Range	0-20000 For 0-20000mg/L	Default: N/A
Power Down Save	N/A	

Note:Total Dissolved Solid

Example:When REGISTER = 0x0702 (HEX format), then VALUE=(0x07*256+0x02)=1794mg/L,

TDS is derived by EC, TDS=EC* TDSCOFF, in which TDSCOFF is a coefficient, please refer to

TDSCOFF.

EPSILON--- EPSILON		
Data Range	88-8188 for 0.88-81.88	Default: N/A
Power Down Save	N/A	

Note:Epsilon

Example:When REGISTER = 0x0702 (HEX format), then VALUE=(0x07*256+0x02)/100=17.94, VWC is derived by EPSILON, VWC is a function of EPSILON. This value is always used for self calibration usage.

TEMPUNIT---Temperature Unit		
Data Range	0:°C 1:°F	Default: 0
Power Down Save	YES	

Note:Temperature Unit.

ECTEMPCOFF---EC Temperature Compensation Coefficient		
Data Range	0-100 for 0.0%-10.0%	Default: 20(2%)
Power Down Save	YES	

Note:EC Temperature Compensation Coefficient

SALINITYCOFF---Salinity Coefficient		
Data Range	0-100 for 0.00-1.00	Default: 55(0.55)
Power Down Save	YES	

Note:Salinity Coefficient.

TDSCOFF---TDS Coefficient		
Data Range	0-100 for 0.00-1.00	Default: 50(0.50)
Power Down Save	YES	

Note:TDS Coefficient.

MEASMUREMENTMETHOD---Measure Method		
Data Range	0: Continuous 1: Request	Default: 1
Power Down Save	YES	

Note: In Continuous mode, the sensor always converts the VWC, EC and Temperature and updates the internal data and is ready for reading. In Request mode, the sensor converts the VWC, EC and Temperature data by receiving the data request command from the master device.

SLAVEADDRESS --- Modbus Slave Address		
Data Range	0-255	Default: 1
Power Down Save	YES	

Note: Please re-power on the sensor to take effect after set.

BAUDRATE --- Serial Comm Baudrate		
Data Range	0-5 0: 1200bps 1: 2400bps 2: 4800bps 3: 9600bps 4: 19200bps 5: 38400bps	Default: 3
Power Down Save	YES	

Note: Please re-power on the sensor to take effect after set.

PROTOCOL --- Serial Comm Protocol		
Data Range	0-1 0:Modbus RTU 1:Modbus ASCII	Default: 0
Power Down Save	YES	

Note: Please re-power on the sensor to take effect after set.

PARITY --- Serial Comm Parity		
Data Range	0-2 0:NONE 1:EVEN 2:ODD	Default: 0
Power Down Save	YES	

Note: Please re-power on the sensor to take effect after set.

DATABITS --- Serial Comm Databits		
Data Range	1 1:8 databits	Default: 1
Power Down Save	YES	

Note: Please re-power on the sensor to take effective after set.

STOPBITS --- Serial Comm Stopbits		
Data Range	0-1 0:1 stopbit 1:2 stopbits	Default: 0
Power Down Save	YES	

Note: Please re-power on the sensor to take effective after set.

RESPONSEDELAY --- Serial Comm Response Delay		
Data Range	0-255 for 0-2550 milliseconds, 0 for disabled	Default: 0
Power Down Save	YES	

Note: Please re-power on the sensor to take effective after set.

Note: Sensor will delay a period before response to master request command.

Example: When set to 5 and receive a request from master device, then sensor will delay 5*10ms=50ms, then response to master.

ACTIVEOUTPUTINTERVAL --- Serial Comm Active Output Interval time		
Data Range	0-255 for 0-255 seconds, 0 for disabled	Default: 0
Power Down Save	YES	

Note: Please re-power on the sensor to take effective after set.

Note: Sensor will output the data actively without any master request command.

Note: Only ONE sensor should be on RS485 network, or there will be data collision and corrupt the data on line.

Note: Refer to SETTING mode to exit the Active Output Mode.

Example: When set to 5 then sensor will output the data every 5 seconds without any master request command.

7.4 Modbus Function Code

For description below, data started with 0X/0x means that it's in HEX format.

7.4.1 Function Code 3 Protocol Example

Master Request:AA 03 RRRR NNNN CCCC

AA	1 byte	Slave Address,0-255
0x03	1 byte	Function Code 3
RRRR	2 byte	Starting Register Addr
NNNN	2 byte	Quantity of Register to read
CCCC	2 byte	CRC CHECKSUM

Slave Response:AA 03 MM VV0 VV1 VV2 VV3... CCCC

AA	1 byte	Slave Address,0-255
0x03	1 byte	Function Code 3
MM	1 byte	Register Data Byte Count
VV0,VV1	2 byte	Register Value (High8bits first)
VV2,VV3	2 byte	Register Value (High8bits first)
...	...	Register Value (High8bits first)
CCCC	2 byte	CRC CHECKSUM

Example:Read register 0x0200-0x0201,that is slave address and baudrate.

Master Request:01 03 0200 0002 C5B3

Slave Addr.	1 byte	0x01
Function Code	1 byte	0x03
Starting Register Addr.	2 byte	0x0200
Quantity of Register to read	2 byte	0x0002
Checksum	2 byte	0xC5B3

Slave Response:01 03 04 00 01 00 03 EB F2

Slave Addr.	1 byte	0x01
Function Code	1 byte	0x03

Register Data Byte Count	1 byte	0x04
Register Value:	2 byte	0x00(HIGH 8 Bits)
Address		0x01(LOW8 Bits)
Register Value:	2 byte	0x00(HIGH 8 Bits)
Baudrate		0x03(LOW8 Bits)
Checksum	2 byte	0xEBF2

7.4.2 Function Code 4 Protocol Example

Master Request:AA 04 RRRR NNNN CCCC

AA	1 byte	Slave Address,0-255
0x04	1 byte	Function Code 4
RRRR	2 byte	Starting Register Addr
NNNN	2 byte	Quantity of Register to read
CCCC	2 byte	CRC CHECKSUM

Slave Response:AA 04 MM VV0 VV1 VV2 VV3... CCCC

AA	1 byte	Slave Address,0-255
0x04	1 byte	Function Code 4
MM	1 byte	Register Data Byte Count
VV0,VV1	2 byte	Register Value (High8bits first)
VV2,VV3	2 byte	Register Value (High8bits first)
...	...	Register Value (High8bits first)
CCCC	2 byte	CRC CHECKSUM

Example:Read register 0x0000-0x0002,that is temperature, soil moisture, and EC.

Master Request:01 04 0000 0003 B00B

Slave Addr.	1 byte	0x01
Function Code	1 byte	0x04
Starting Register Addr.	2 byte	0x0000
Quantity of Register to read	2 byte	0x0003

Checksum	2 byte	0xB00B
----------	--------	--------

Slave Response:01 04 06 08 90 0E 93 02 4E D2 57

Slave Addr.	1 byte	0x01
Function Code	1 byte	0x04
Register Data Byte Count	1 byte	0x06
Register Value: Temperature	2 byte	0x08(HIGH 8 Bits) 0x90(LOW8 Bits)
Register Value: Soil Moisture	2 byte	0x0E(HIGH 8 Bits) 0x93(LOW8 Bits)
Register Value: EC	2 byte	0x02(HIGH 8 Bits) 0x4E(LOW8 Bits)
Checksum	2 byte	0xD257

Temperature = (0x08*256+0x 90)/100=2192/100=21.92 °C

Soil Moisture = (0x0E*256+0x93)/100=3731/100=37.31%

EC=0x02*256+0x4E=2*256+78 =590 us/cm

7.4.3 Function Code 6 Protocol Example

Master Request:AA 06 RRRR VVVV CCCC

AA	1 byte	Slave Address,0-255
0x06	1 byte	Function Code 6
RRRR	2 byte	Register Addr (High8bits first)
VVVV	2 byte	Register Value (High8bits first)
CCCC	2 byte	CRC CHECKSUM

Slave Response:AA 06 RRRR VVVV CCCC

AA	1 byte	Slave Address,0-255
0x06	1 byte	Function Code 6
RRRR	2 byte	Register Addr (High8bits first)
VVVV	2 byte	Register Value (High8bits first)
CCCC	2 byte	CRC CHECKSUM

Example:Write Register 0x0021,that is set temperature unit to °F .

Request:01 06 0021 0001 1800

Slave Addr.	1 byte	0x01
Function Code	1 byte	0x06
Register Addr.	2 byte	0x0021 (High8bits first)
Register Value	2 byte	0x0001 (High8bits first)
Checksum	2 byte	0x1800

Response:01 06 0021 0001 1800

Slave Addr.	1 byte	0x01
Function Code	1 byte	0x06
Register Addr.	2 byte	0x0021 (High8bits first)
Register Value	2 byte	0x0001 (High8bits first)
Checksum	2 byte	0x1800

7.4.4 Function Code 16 Protocol Example

Master Request:AA 10 RRRR NNNN MM VVVV1 VVVV2 ...CCCC

AA	1 byte	Slave Address,0-255
0x10	1 byte	Function Code 0x10
RRRR	2 byte	Starting Register Addr
NNNN	2 byte	Quantity of Register to write
MM	1 byte	Register Data Byte Count
VVVV1	2 byte	Register Value(High8bits first)
VVVV2	2 byte	Register Value(High8bits first)
...	...	Register Value(High8bits first)
CCCC	2 byte	CRC CHECKSUM

Slave Response:AA 10 RRRR NNNN CCCC

AA	1 byte	Slave Address,0-255
0x10	1 byte	Function Code 0x10
RRRR	2 byte	Starting Register Addr
NNNN	2 byte	Quantity of Register to write
CCCC	2 byte	CRC CHECKSUM

Example:Write Register 0x0200-0x0201,that is set slave address to 1,and baudrate to

19200bp.

Master Request:01 10 0200 0002 04 0001 0004 BACC

0x01	1 byte	Slave Addr.
0x10(HEX)	1 byte	Function Code 0x10
0x0200	2 byte	Starting Register Addr
0x0002	2 byte	Quantity of Register to write
0x04	1 byte	Register Data Byte Count
0x0001	2 byte	Register Value: Slave Address 1
0x0004	2 byte	Register Value: Baudrate 19200bps
0xBACC	2 byte	CRC CHECKSUM

Salve Response:01 10 0200 0002 4070

0x01	1 byte	Slave Addr.
0x10(HEX)	1 byte	Function Code 0x10
0x0200	2 byte	Starting Register Addr(High8bits first)
0x0002	2 byte	Quantity of Register to write(High8bits first)
0x4070	2 byte	CRC CHECKSUM

8 Software Configuration Utility

8.1 Hardwar Setup

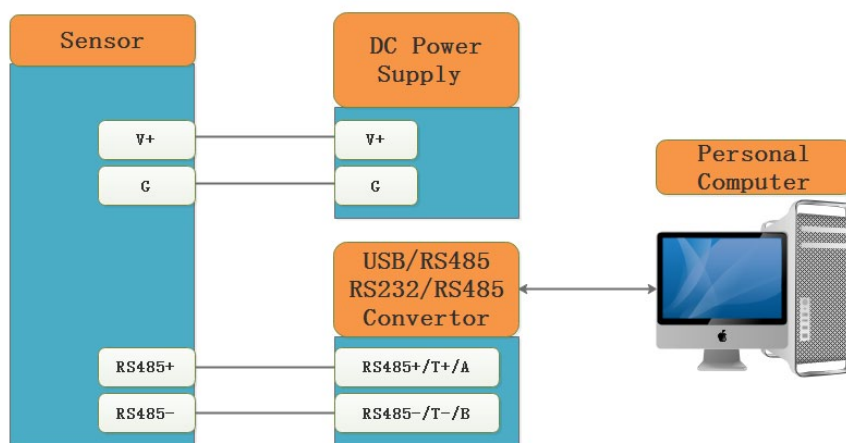

8.2 Universal Modbus Comm Utility

You can use software listed below to try reading/writing the register of sensor, <https://github.com/ed-chemnitz/qmodbus/releases>

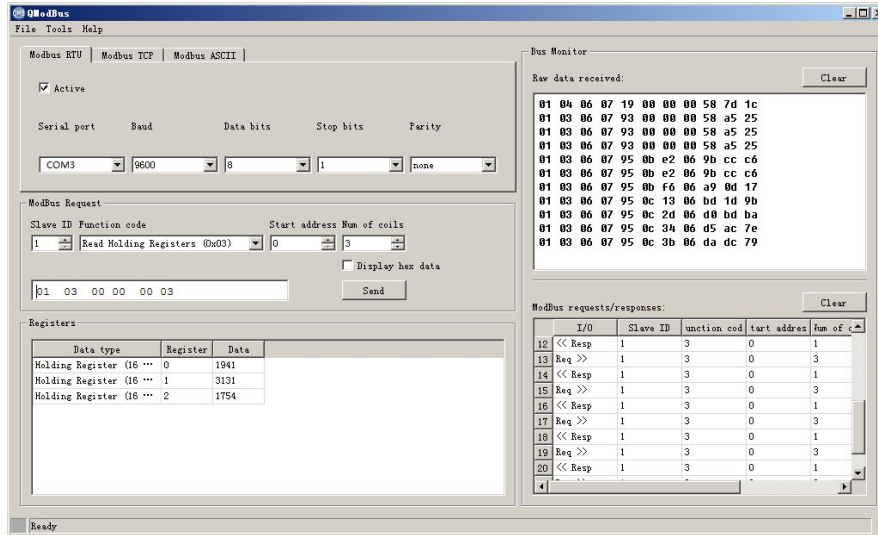

8.3 SensorOneSet Configuration Utility

SensorOneSet is a configuration utility to read/set sensor config for all of our serial communication sensor products. Please contact us if you need the English version.

Appendix

Copyright and Trademark

This document is copyrighted, 2019, by Dalian Endeavour Technology Co., Ltd. All rights are reserved. Dalian Endeavour Technology Co., Ltd. reserves the right to make improvements to the products described in this manual at any time without notice. No part of this manual may be reproduced, copied, translated or transmitted in any form or by any means without the prior written permission. Information provided in this manual is intended to be accurate and reliable. However, Dalian Endeavour Technology Co., Ltd. assumes no responsibility for its use, nor for any infringements upon the rights of third parties, which may result from its use.

INFWIN® is the trademark of Dalian Endeavour Technology Co., Ltd.

Version Control

Date	Version	Comment	Updated by
2015-04-23	V1.0	Initial Creation	fg49597
2016-08-16	V1.1	Update	sl51930
2018-04-16	V1.2	Update Voltage supply range(E:2-5.5V)	fg49597