

PYR20

Solar Radiation/Pyranometer Sensor

User Manual



Index

1	Customer Support.....	3
2	Introduction	4
3	Wiring diagrams	5
4	Dimension and Ordering Infomation	7
	4.1 Dimension	7
	4.2 Ordering Infomation	8
5	Safty ,Care and Installation	9
	5.1 Care and Safty	9
	5.2 Installation	9
6	Output Signal Conversion	10
7	RS485 Modbus Protocol	11
	7.1 Modbus Protocol	11
	7.2 Modbus Register	11
	7.3 Modbus Register Detail Descripton	12
	7.4 Modbus Function Code	14
	7.4.1 Function Code 3 Protocol Example	15
	7.4.2 Function Code 4 Protocol Example	16
	7.4.3 Function Code 6 Protocol Example	17
	7.4.4 Function Code 16 Protocol Example	18
8	Software Configuration Utility.....	19
	8.1 Hardwar Setup	19
	8.2 Universal Modbus Comm Utility	19
	8.3 SensorOneSet Configuration Utility	20
	Appendix	21
	Copyright and Trademark	21
	Version Control	21

1 Customer Support

Thank you very much for your order. Our success comes from the continuous faith in the excellence of our products and services, something we are committed to and would never sacrifice. Our customer service, especially in the after sales phase, guarantees the satisfaction of our clients. In line with this strategy, we appreciate that you can share with us your feedback at any time for our improvement, be it positive or negative, so if we can serve you better in anyway, please do inform us.

Website

<http://www.infwin.com>

E-Mail

infwin@163.com

Telephone

+86-411-66831953, +86-4000-511-521

Fax

+86-411-82388125

2 Introduction

PYR20 pyranometer, or solar Radiation Sensor, measures global radiation of both direct and diffusion of solar irradiance. The internal temperature compensation minimizing the error caused by heating of the sensor. Each sensor is calibrated against Eppley Precision Spectral Pyranometer and offers excellent accuracy and consistency. The sensor is applicable for science research, solar power , greenhouse, weather station etc.

- Measurement range to 2000W/m², Spectral range 400-1100nm
- Output interface with RS485, Voltage or Current
- Temperature compensated
- Level indicator and spring loaded for installation
- Water proof to IP66 can be used outdoor
- High accuracy and consistency with excellent stability
- Reverse power protection and Built-in TVS/ESD protection

Specifications			
Output Interface	Analog Voltage 0-2V (Output resistance ~0ohm)	Analog Current 4-20mA (Load Resistor<500ohm)	RS485 Modbus-RTU
Power Supply	3.9-30V/DC	12-30V/DC	3.9-30V/DC
Power Consumption	7mA@24V DC	30mA@24V DC (with 20mA output signal)	7mA@24V DC
Pyr Range	Range:0-2000W/m ² , Accuracy 5%, Resolution:1W/m ²		
Spectral Range	400-1100nm		
Direction Error	Percent of reading: ±3% (0 - ±70°); ±10% (±70 - ±85°)		
IP Ratings	IP66		
Operating Temperature	-40~85°C		
Installation	Screw hole * 3		
Cable Length	2 meters, or Customize		
Dimension	75*55*58mm		

3 Wiring diagrams

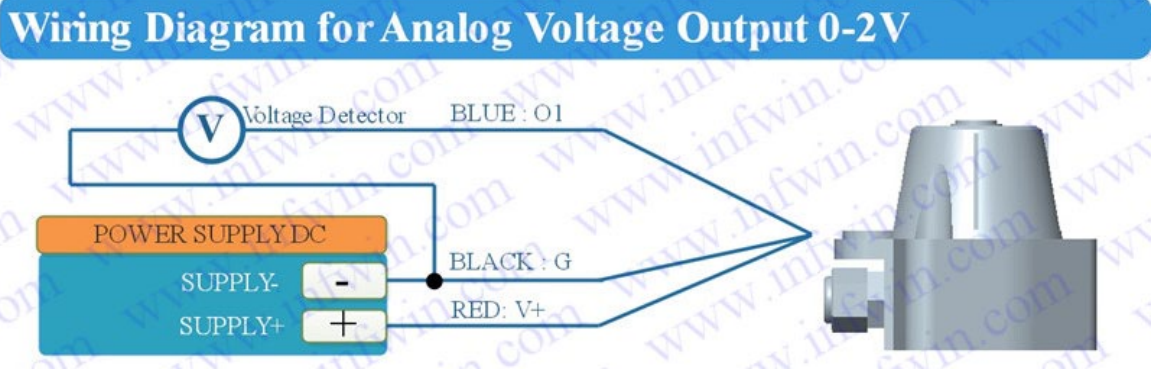
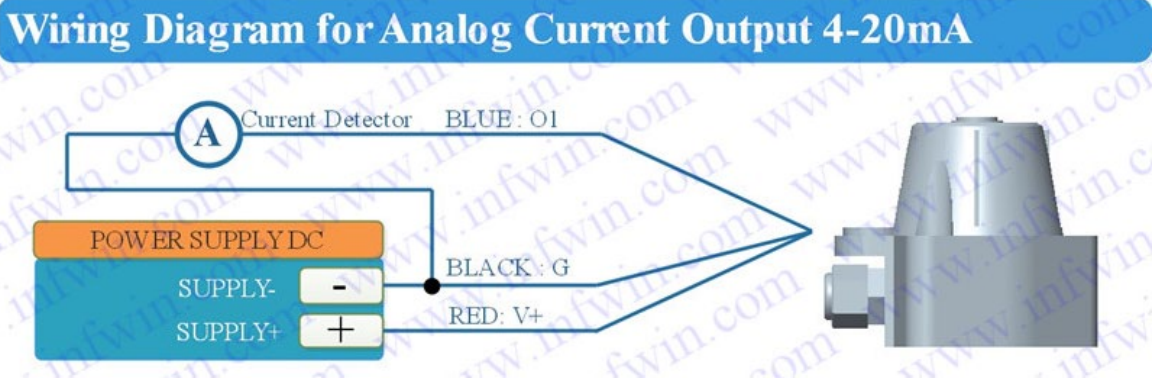
Type	Wiring diagram
Analog Voltage Output	<p>Red (V+): Power Supply + Black (G): Power Supply - Blue (O1): Analog Output</p> <p style="text-align: center;">Wiring Diagram for Analog Voltage Output 0-2V</p> 
Analog Current Output	<p>Red (V+): Power Supply + Black (G): Power Supply - Blue (O1): Analog Output</p> <p style="text-align: center;">Wiring Diagram for Analog Current Output 4-20mA</p> 
RS485 Modbus	<p>Red (V+): Power Supply + Black (G): Power Supply - Yellow (T+): RS485+/A/T+ White (T-): RS485-/B/T-</p>

Wiring Diagram for RS485 Modbus

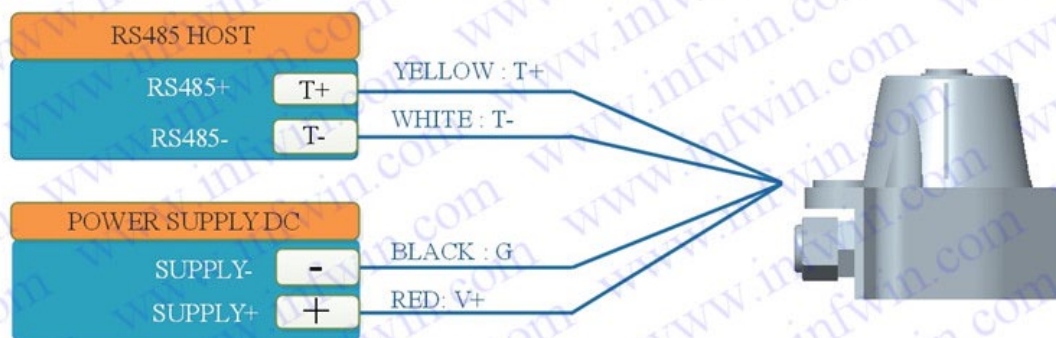

ALL RS485 communication parameters (Mosbus Slave Address, baudrate, parity, databits, stopbits) are set in internal register and can be saved when power down, the factory setting is ADDRESS=1, BAUDRATE=9600bps, PARITY=NONE, DATABITS=8bits, STOPBITS=1bit;

Sometimes you may FORGET the communication settings, In this case, you can open the shield module and press the SET button for more that 3 seconds, then all the communication parameters reset to factory setting, then communicating with the sensor using the factory setting to set your desired settings. Please re-power up the sensor to make the settings effective.

4 Dimension and Ordering Information

4.1 Dimension

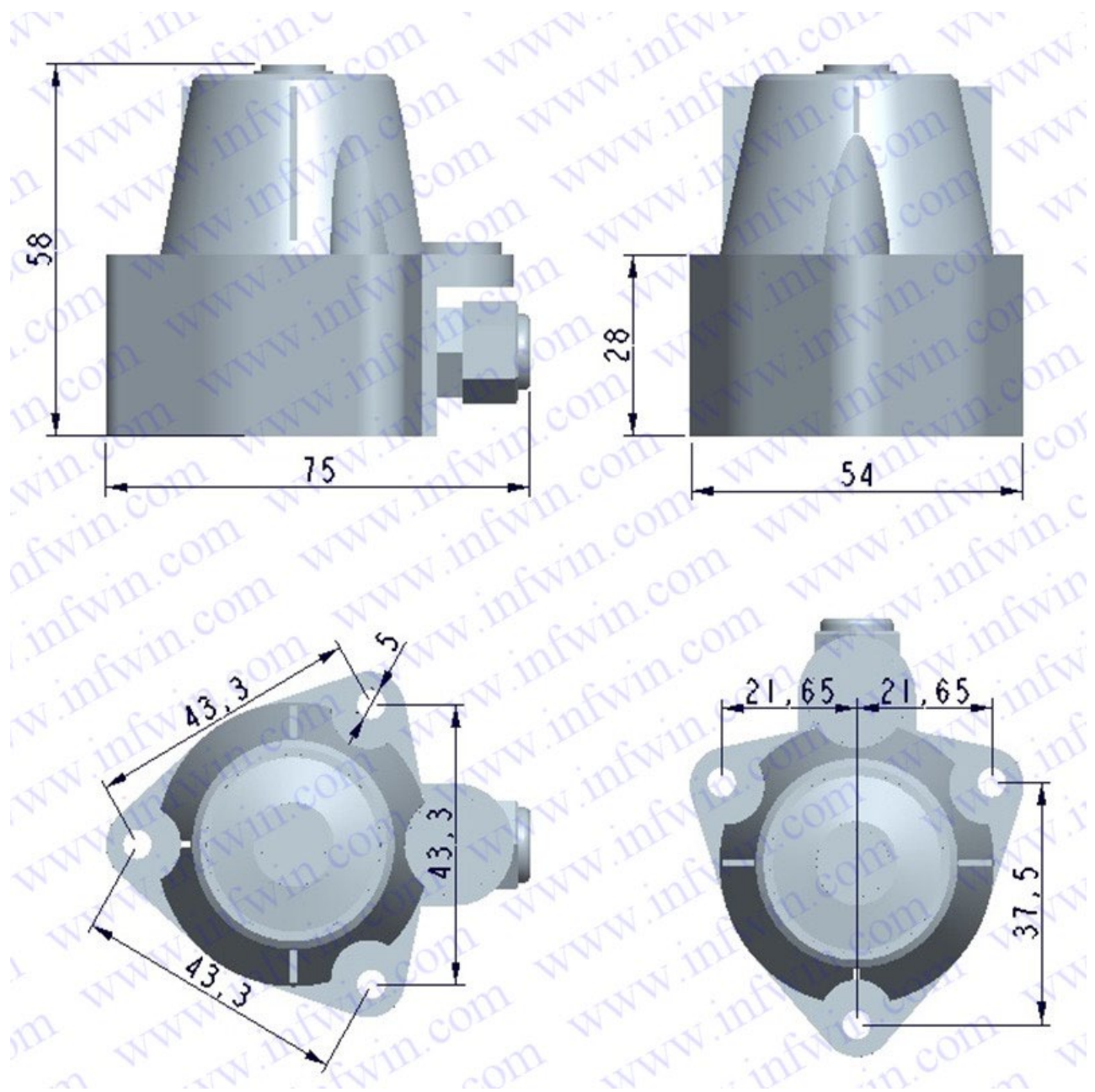

Unit: mm

4.2 Ordering Information

Parameters	Code	Comments
Code 1:Product Series	PYR20	PYR20 Pyranometer series
Code 2: Range	A B	2000W/m2 Customize
Code 3: Power Supply	A B	3.9-30V DC 2.7-16V DC
Code 4: Output Interface	A B C D E F G	Analog Voltage 0-2V Analog Current 4-20mA RS485,Modbus-RTU RS485,Modbus-RTU & Analog Voltage 0-2V RS485,Modbus-RTU & Analog Current 4-20mA SDI-12 Customize
Code 5: Cable Length	002 XXX	2 meters Customize, XXX is required cable length(Unit: meter)
Ordering Code Example: PYR20 pyranometer sensor,Range 2000W/m2,Power Supply 3.9-30V DC,Output Interface RS485 ModbusRTU,Cable length 5 meters.Ordering Code is:PYR20-AAC005		

5 Safty ,Care and Installation

5.1 Care and Safty

Keep the white optical lens on the top of the sensor clean and wiping lens by soft rag. Always checking the horizontal bubble to keep the sensor horizontally placed.

5.2 Installation

Adjusting the screw and checking the horizontal bubble to make the sensor horizontally installed.

6 Output Signal Conversion

Output Interface	Parameters Range	Conversion Formula
Analog Voltage Output 0-2V	SR: 0-2000W/m ²	SR=1000* VLOTAGE. When VOLTEGE=1.0V,then SR =1000*1.00=1000W/m ² .
Analog Current Output 4-20mA	SR: 0-2000W/m ²	SR = 2000 *(CURRENT-4)/16. When CURRENT=12mA,then SR =2000*(12-4)/16=1000 W/m ² .
RS485 Modbus-RTU	SR: 0-2000W/m ²	SR =(REGISTER VALUE).When REGISTER VALUE=1000,then SR = 1000 W/m ² .
Customize	Contact support for customized sensor interface	

NOTE:The unit of VOLTAGE is (V), The unit of CURRENT is (mA).

NOTE: SR is solar radiation or pyranometer value.

7 RS485 Modbus Protocol

7.1 Modbus Protocol

Modbus Protocol is widely used to establish master-slave communication between intelligent devices or sensors. A MODBUS message sent from a master to a slave contains the address of the slave, the function code (e.g. 'read register' or 'write register'), the data, and a check sum (LRC or CRC).

The sensor is RS485 interface with Modbus protocol. The default serial communication settings is slave address 1, modbus rtu, 9600bps, 8 databits and 1 stop bit. All communication settings can be changed with modbus command, and take effective after re-power up the sensor.

Following modbus function code are supported by sensor.

Modbus Function Code 0x03 : used for reading holding register.

Modbus Function Code 0x04 : used for reading input register.

Modbus Function Code 0x06 : used for writing single holding register.

Modbus Function Code 0x10: used for writing multiple holding register.

7.2 Modbus Register

Parameters	Register Addr. (HEX/DEC)	Data Type	Modbus Function Code(DEC)	Range and Comments	Default Value
SR Solar Radiation	0x0000 /0	UINT16 RO	3/4	0-2000 for 0-2000W/m2.	N/A
RESERVED	0x0001 /1	UINT16 RO	3/4	0	0
RESERVED	0x0002 /2	UINT16 RO	3/4	0	0
RESERVED	0x0003 /3	UINT16 RO	3/4	0	0
RESERVED	0x0004 /4	UINT16 RO	3/4	0	0
RESERVED	0x0004 /5	UINT16	3/4	0	0

		RO			
SLAVEADDRESS	0x0200 /512	UINT16 R/W	3/6/16	0-255	1
BAUDRATE	0x0201 /513	UINT16 R/W	3/6/16	0-6 0:1200bps 1:2400bps 2:4800bps 3:9600bps 4:19200bps 5:38400bps	3:9600bps
PROTOCOL	0x0202 /514	UINT16 R/W	3/6/16	0 0:Modbus RTU	0:Modbus RTU
PARITY	0x0203 /515	UINT16 R/W	3/6/16	0-2 0:None 1:Even 2:Odd	0:None Parity
DATABITS	0x0204 /516	UINT16 R/W	3/6/16	1 1:8 databits	1:8 databits
STOPBITS	0x0205 /517	UINT16 R/W	3/6/16	0-1 0:1 stopbit 1:2 stopbits	0:1 stopbit
RESPONSEDELAY	0x0206 /518	UINT16 R/W	3/6/16	0-255 for 0-2550 milliseconds	0
ACTIVEOUTPUTINTERVAL	0x0207 /519	UINT16 R/W	3/6/16	0-255 for 0-255 seconds.	0

NOTE: UINT16:16 bit unsigned integer, INT16:16bit signed integer

NOTE: R: Register is Readonly, R/W: Register is Read/Write

NOTE: HEX is Hexadecimal (data with 0x/0X prefix), DEC is Decimal

7.3 Modbus Register Detail Descripton

SR --- Solar Radiation		
Data Range	0-2000 for 0-2000W/m2.	Default: N/A
Power Down Save	N/A	

Note: Pyranometer value

Example:When REGISTER = 0x0702 (HEX format), then

VALUE=(0x07*256+0x02)/100=1794W/m2.

SLAVEADDRESS --- Modbus Slave Address		
Data Range	0-255	Default: 1
Power Down Save	YES	

Note: Please re-power on the sensor to take effective after set.

BAUDRATE --- Serial Comm Baudrate		
Data Range	0-5 0: 1200bps 1: 2400bps 2: 4800bps 3: 9600bps 4: 19200bps 5: 38400bps	Default: 3
Power Down Save	YES	

Note: Please re-power on the sensor to take effective after set.

PROTOCOL --- Serial Comm Protocol		
Data Range	0 0:Modbus RTU	Default: 0
Power Down Save	YES	

Note: Please re-power on the sensor to take effective after set.

PARITY --- Serial Comm Parity		
Data Range	0-2 0:NONE 1:EVEN 2:ODD	Default: 0
Power Down Save	YES	

Note: Please re-power on the sensor to take effective after set.

DATABITS --- Serial Comm Databits		
Data Range	1 1:8 databits	Default: 1

Power Down Save	YES	
-----------------	-----	--

Note: Please re-power on the sensor to take effective after set.

STOPBITS --- Serial Comm Stopbits		
Data Range	0-1 0:1 stopbit 1:2 stopbits	Default: 0
Power Down Save	YES	

Note: Please re-power on the sensor to take effective after set.

RESPONSEDELAY --- Serial Comm Response Delay		
Data Range	0-255 for 0-2550 milliseconds, 0 for disabled	Default: 0
Power Down Save	YES	

Note: Please re-power on the sensor to take effective after set.

Note: Sensor will delay a period before response to master request command.

Example: When set to 5 and receive a request from master device, then sensor will delay 5*10ms=50ms, then response to master.

ACTIVEOUTPUTINTERVAL --- Serial Comm Active Output Interval time		
Data Range	0-255 for 0-255 seconds, 0 for disabled	Default: 0
Power Down Save	YES	

Note: Please re-power on the sensor to take effective after set.

Note: Sensor will output the data actively without any master request command.

Note: Only ONE sensor should be on RS485 network, or there will be data collision and corrupt the data on line.

Note: Refer to SETTING mode to exit the Active Output Mode.

Example: When set to 5 then sensor will output the data every 5 seconds without any master request command.

7.4 Modbus Function Code

For description below, data started with 0X/0x means that it's in HEX format.

7.4.1 Function Code 3 Protocol Example

Master Request:AA 03 RRRR NNNN CCCC

AA	1 byte	Slave Address,0-255
0x03	1 byte	Function Code 3
RRRR	2 byte	Starting Register Addr
NNNN	2 byte	Quantity of Register to read
CCCC	2 byte	CRC CHECKSUM

Slave Response:AA 03 MM VV0 VV1 VV2 VV3... CCCC

AA	1 byte	Slave Address,0-255
0x03	1 byte	Function Code 3
MM	1 byte	Register Data Byte Count
VV0,VV1	2 byte	Register Value (High8bits first)
VV2,VV3	2 byte	Register Value (High8bits first)
...	...	Register Value (High8bits first)
CCCC	2 byte	CRC CHECKSUM

Example:Read register 0x0200-0x0201,that is slave address and baudrate.

Master Request:01 03 0200 0002 C5B3

Slave Addr.	1 byte	0x01
Function Code	1 byte	0x03
Starting Register Addr.	2 byte	0x0200
Quantity of Register to read	2 byte	0x0002
Checksum	2 byte	0xC5B3

Slave Response:01 03 04 00 01 00 03 EB F2

Slave Addr.	1 byte	0x01
Function Code	1 byte	0x03
Register Data Byte Count	1 byte	0x04
Register Value:	2 byte	0x00(HIGH 8 Bits)
Address		0x01(LOW8 Bits)

Register Value:	2 byte	0x00(HIGH 8 Bits)
Baudrate		0x03(LOW8 Bits)
Checksum	2 byte	0xEBF2

7.4.2 Function Code 4 Protocol Example

Master Request: AA 04 RRRR NNNN CCCC

AA	1 byte	Slave Address,0-255
0x04	1 byte	Function Code 4
RRRR	2 byte	Starting Register Addr
NNNN	2 byte	Quantity of Register to read
CCCC	2 byte	CRC CHECKSUM

Slave Response: AA 04 MM VV0 VV1 VV2 VV3... CCCC

AA	1 byte	Slave Address,0-255
0x04	1 byte	Function Code 4
MM	1 byte	Register Data Byte Count
VV0,VV1	2 byte	Register Value (High8bits first)
VV2,VV3	2 byte	Register Value (High8bits first)
...	...	Register Value (High8bits first)
CCCC	2 byte	CRC CHECKSUM

Example:Read register 0x0000,that is solar radiation value:

Master Request: 01 04 0000 0001 31CA

Slave Addr.	1 byte	0x01
Function Code	1 byte	0x04
Starting Register Addr.	2 byte	0x0000
Quantity of Register to read	2 byte	0x0001
Checksum	2 byte	0x31CA

Slave Response: 01 04 02 0010 B8FC

Slave Addr.	1 byte	0x01
-------------	--------	------

Function Code	1 byte	0x04
Register Data Byte Count	1 byte	0x02
Register Value:	2 byte	0x00(HIGH 8 Bits)
Pyranometer Value		0x10(LOW8 Bits)
Checksum	2 byte	0xB8FC

Solar Radiation=0x00*256+0x10=16W/m2.

7.4.3 Function Code 6 Protocol Example

Master Request:AA 06 RRRR VVVV CCCC

AA	1 byte	Slave Address,0-255
0x06	1 byte	Function Code 6
RRRR	2 byte	Register Addr (High8bits first)
VVVV	2 byte	Register Value (High8bits first)
CCCC	2 byte	CRC CHECKSUM

Slave Response:AA 06 RRRR VVVV CCCC

AA	1 byte	Slave Address,0-255
0x06	1 byte	Function Code 6
RRRR	2 byte	Register Addr (High8bits first)
VVVV	2 byte	Register Value (High8bits first)
CCCC	2 byte	CRC CHECKSUM

Example:Write Register 0x0200,that is change modbus slave address to 2.

Master Request: 01 06 0200 0002 09B3

Slave Addr.	1 byte	0x01
Function Code	1 byte	0x06
Register Addr.	2 byte	0x0200
Register Value	2 byte	0x0002
Checksum	2 byte	0x09B3

Slave Response: 01 06 0200 0002 09B3

Slave Addr.	1 byte	0x01
-------------	--------	------

Function Code	1 byte	0x06
Register Addr.	2 byte	0x0200
Register Value	2 byte	0x0002
Checksum	2 byte	0x09B3

7.4.4 Function Code 16 Protocol Example

Master Request:AA 10 RRRR NNNN MM VVVV1 VVVV2 ...CCCC

AA	1 byte	Slave Address,0-255
0x10	1 byte	Function Code 0x10
RRRR	2 byte	Starting Register Addr
NNNN	2 byte	Quantity of Register to write
MM	1 byte	Register Data Byte Count
VVVV1	2 byte	Register Value(High8bits first)
VVVV2	2 byte	Register Value(High8bits first)
...	...	Register Value(High8bits first)
CCCC	2 byte	CRC CHECKSUM

Slave Response:AA 10 RRRR NNNN CCCC

AA	1 byte	Slave Address,0-255
0x10	1 byte	Function Code 0x10
RRRR	2 byte	Starting Register Addr
NNNN	2 byte	Quantity of Register to write
CCCC	2 byte	CRC CHECKSUM

Example:Write Register 0x0200-0x0201,that is set slave address to 1,and baudrate to 19200bp.

Master Request:01 10 0200 0002 04 0001 0004 BACC

0x01	1 byte	Slave Addr.
0x10(HEX)	1 byte	Function Code 0x10
0x0200	2 byte	Starting Register Addr
0x0002	2 byte	Quantity of Register to write
0x04	1 byte	Register Data Byte Count
0x0001	2 byte	Register Value: Slave Address 1

0x0004	2 byte	Register Value: Baudrate 19200bps
0xBACC	2 byte	CRC CHECKSUM

Salve Response:01 10 0200 0002 4070

0x01	1 byte	Slave Addr.
0x10(HEX)	1 byte	Function Code 0x10
0x0200	2 byte	Starting Register Addr(High8bits first)
0x0002	2 byte	Quantity of Register to write(High8bits first)
0x4070	2 byte	CRC CHECKSUM

8 Software Configuration Utility

8.1 Hardwar Setup

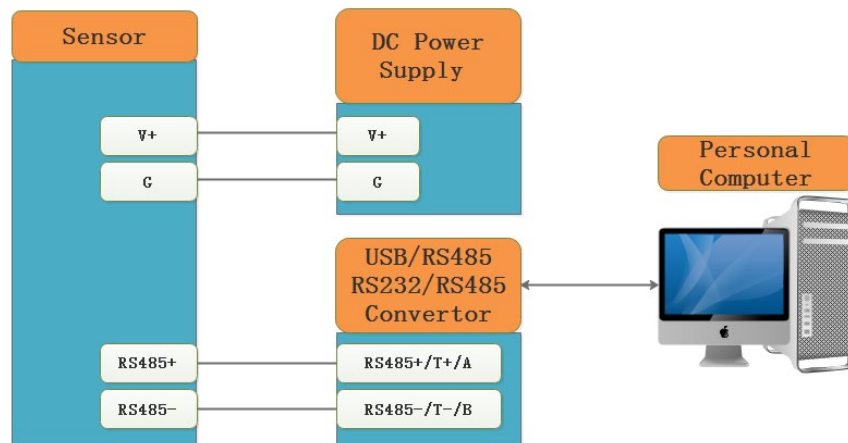

8.2 Universal Modbus Comm Utility

You can use software listed below to try reading/writing the register of sensor, <https://github.com/ed-chemnitz/qmodbus/releases>

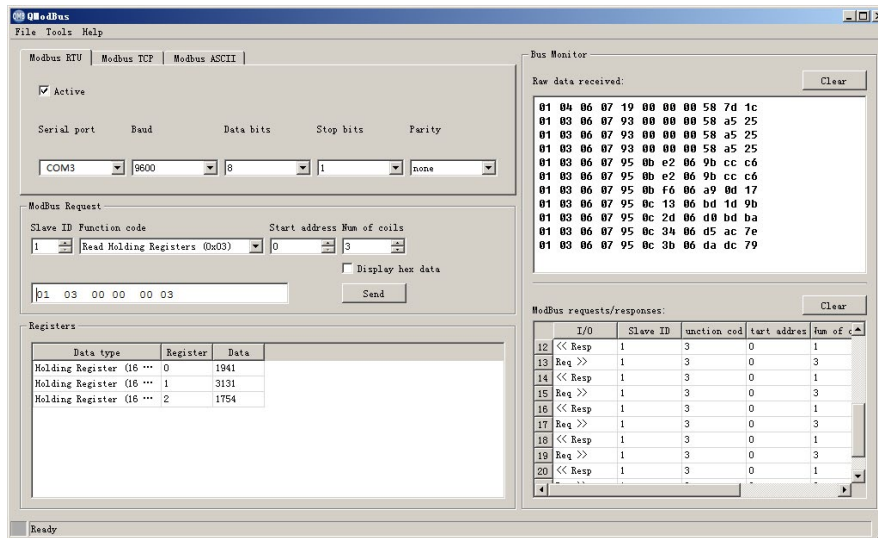

8.3 SensorOneSet Configuration Utility

SensorOneSet is a configuration utility to read/set sensor config for all of our serial communication sensor products. Please contact us if you need the English version.

Appendix

Copyright and Trademark

This document is copyrighted, 2019, by Dalian Endeavour Technology Co., Ltd. All rights are reserved. Dalian Endeavour Technology Co., Ltd. reserves the right to make improvements to the products described in this manual at any time without notice. No part of this manual may be reproduced, copied, translated or transmitted in any form or by any means without the prior written permission. Information provided in this manual is intended to be accurate and reliable. However, Dalian Endeavour Technology Co., Ltd. assumes no responsibility for its use, nor for any infringements upon the rights of third parties, which may result from its use.

INFWIN® is the trademark of Dalian Endeavour Technology Co., Ltd.

Version Control

Date	Version	Comment	Updated by
2016-06-02	V1.0	Initial Creation	fg49597